

## CONSOLE WATER SOURCE HEAT PUMP (CHPW) CERTIFIED DRAWING

DWG. NO.  
**Submittal Template CHPW**  
REV. - 01

PROJECT	DATE	BY	REVISIONS			
PURCHASER	P.O. #	QTY	DATE	BY	DESCRIPTION	
ARCHITECT	SHIPPING DATES					
ENGINEER						
HVAC CONTR.						
GEN. CONTR.						

DESIGNATION	MODEL NUMBER	QTY
<b>TOTAL</b>		

### UNIT SPECIFICATIONS+ PERFORMANCE DATA

MODEL	COOLING CAPACITY*	COOLING EER	HEATING CAPACITY**	HEATING COP	TYPICAL CFM
5CHPW07	7,700	13.7	9,110	4.6	250
5CHPW09	9,800	13.6	12,200	4.4	300
5CHPW13	13,000	14.5	15,750	4.5	400
8CHPW07	7,700	13.7	9,110	4.6	250
8CHPW09	9,800	13.6	12,200	4.4	300
8CHPW13	13,000	14.5	15,750	4.5	400
8CHPW16	16,500	14.2	20,600	4.5	500
8CHPW19	20,000	14.4	27,250	4.4	550

### GENERAL NOTES

### CUSTOM NOTES

1:

\* BTUH @ 80.6°F DB, 66.2°F WB EAT; 86°F EWT @ 2 GPM

\*\* BTUH @ 68°F DB, 59°F WB EAT; 68°F EWT

### PHYSICAL DATA

MODEL	5CHPW07	5CHPW09	5CHPW13	8CHPW07	8CHPW09	8CHPW13	8CHPW16	8CHPW19
COMPRESSOR TYPE (1 EA)	ROTARY							
REFRIGERANT	R410A							
REFRIGERANT FACTORY CHARGE (oz)	16	17.6	24.7	16	17.6	24.7	24.7	30
FAN MOTOR (HP)	1/20	1/20	1/12	1/20	1/12	1/12	1/8	1/6
BLOWER WHEEL SIZE (DIAMETERXWIDTH) (IN)	5.25" X 6.25"							
WATER CONNECTION (IN)	1/2" NPT							
AIR COIL DIMENSION (IN)	19.5X10.0	19.5X10.0	19.5X10.0	19.5X10.0	19.5X10.0	19.5X10.0	27.5X10.0	27.5X10.0
STANDARD FILTER-1/2" (IN)	22.75X10.0	22.75X10.0	22.75X10.0	22.75X10.0	22.75X10.0	22.75X10.0	30.75X10.0	30.75X10.0
WEIGHT (LB)	170	175	180	170	180	180	190	210

## CONSOLE WATER SOURCE HEAT PUMP (CHPW) CERTIFIED DRAWING

DWG. NO.  
**Submittal Template CHPW**  
REV. - 01

PROJECT	DATE	BY	REVISIONS			
PURCHASER	P.O. #	QTY	DATE	BY	DESCRIPTION	
ARCHITECT	SHIPPING DATES					
ENGINEER						
HVAC CONTR.						
GEN. CONTR.						

### UNIT SPECIFICATIONS+

#### TYPICAL WATER SIDE DATA

TABLE 3

MODEL	5CHPW07	5CHPW09	5CHPW13	8CHPW07	8CHPW09	8CHPW13	8CHPW16	8CHPW19
FLOW RATE (GPM)	1.5	1.5	2.0	1.5	1.5	2.0	2.5	3.1
WATER CONNECTION SIZE (IN)	1/2 NPT							
CONDENSATE HOSE CONNECTION SIZE (IN)	5/8"							

#### ELECTRICAL DATA

TABLE 4

MODEL	VOLTAGE/HZ-PHASE	TOTAL UNIT FLA	MIN CIRCUIT AMPS	MAX FUSE/HACR
5CHPW07	115/60-1	5.1	7.57	15
5CHPW09	115/60-1	7.3	8.7	15
5CHPW13	115/60-1	15.5	19.0	30
8CHPW07	208-230/60-1	2.8	5	15
8CHPW09	208-230/60-1	5.2	6.2	15
8CHPW13	208-230/60-1	5.8	6.9	15
8CHPW16	208-230/60-1	8.5	10.1	15
8CHPW19	208-230/60-1	10.2	12.3	20

#### AIR FLOW CORRECTION TABLE

TABLE 5

	% OF RATED AIR FLOW	70%	75%	80%	85%	90%	95%	100%	105%
COOLING FACTORS	TOTAL CAPACITY	0.92	0.93	0.95	0.96	0.97	0.99	1.00	1.02
	SENSIBLE CAPACITY	0.80	0.83	0.87	0.90	0.93	0.97	1.00	1.04
	POWER	0.97	0.97	0.98	0.99	0.99	1.00	1.00	1.01
	HEAT REJECTION	0.94	0.95	0.96	0.97	0.98	0.99	1.00	1.01
HEATING FACTORS	HEATING CAPACITY	0.94	0.95	0.96	0.97	0.98	0.99	1.00	1.01
	POWER	1.08	1.06	1.05	1.04	1.02	1.01	1.00	0.99
	HEAT EXTRACTION	0.93	0.95	0.96	0.97	0.98	0.99	1.00	1.01

## CONSOLE WATER SOURCE HEAT PUMP (CHPW) CERTIFIED DRAWING

DWG. NO.  
**Submittal Template CHPW**  
REV. - 01

PROJECT	DATE	BY	REVISIONS				
PURCHASER	P.O. #	QTY	DATE	BY	DESCRIPTION		
ARCHITECT	SHIPPING DATES						
ENGINEER							
HVAC CONTR.							
GEN. CONTR.							

### UNIT SPECIFICATIONS+

#### AIR TEMPERATURE CORRECTION TABLE

TABLE 6

HEATING								
EAT DB (°F)	45	50	55	60	65	70	75	80
HEATING CAPACITY FACTOR	1.11	1.09	1.06	1.04	1.02	1.00	0.98	0.95
POWER FACTOR	0.77	0.81	0.86	0.91	0.95	1.00	1.05	1.10
HEAT EXTRACTION FACTOR	1.18	1.14	1.11	1.07	1.04	1.00	0.96	0.92

TABLE 7

COOLING						
EAT WB (°F)	60	65	67	70	75	
TOTAL CAPACITY FACTOR	0.85	0.96	1.00	1.06	1.17	
SENSIBLE CAPACITY FACTOR EAT DB	70	0.85	0.62	0.52	-	-
	75	1.09	0.86	0.76	0.62	-
	80	1.33	1.09	1.00	0.86	0.63
	85	*	1.33	1.23	1.09	0.85
	90	*	*	1.48	1.34	1.10
	95	*	*	*	1.56	1.32
POWER FACTOR	1.00	1.00	1.00	1.00	1.01	
HEAT REJECTION FACTOR	0.90	0.97	1.00	1.05	1.12	

DB - DRY BULB AIR TEMPERATURE  
 WB - WET BULB AIR TEMPERATURE  
 EAT - ENTERING AIR TEMPERATURE  
 ALL TEMPERATURES ARE IN °F  
 \* = SENSIBLE CAPACITY EQUALS TOTAL CAPACITY

REVISIONS			
REV.	DESCRIPTION	BY	DATE

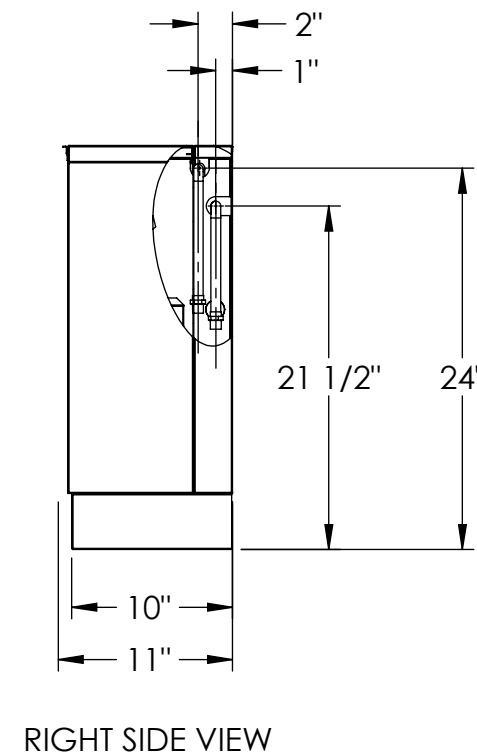
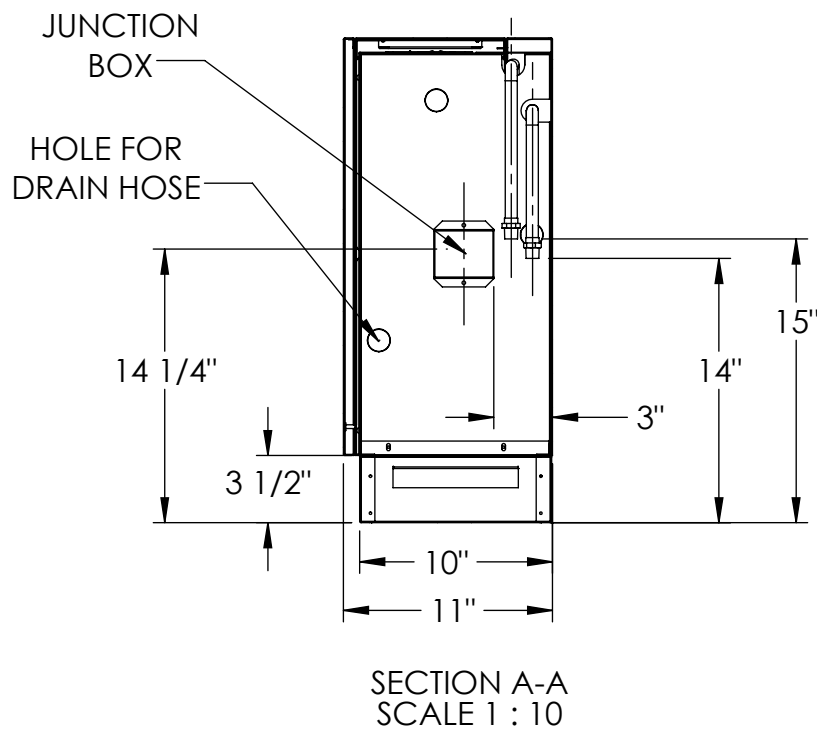
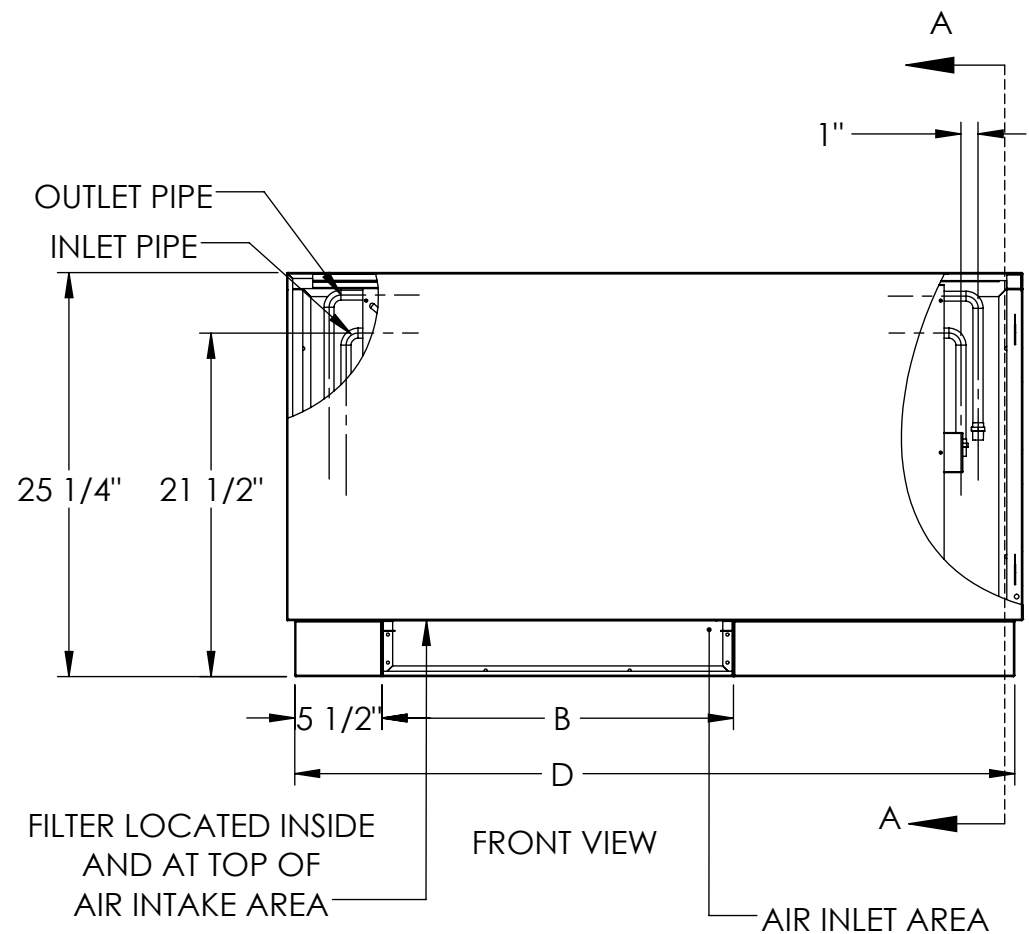
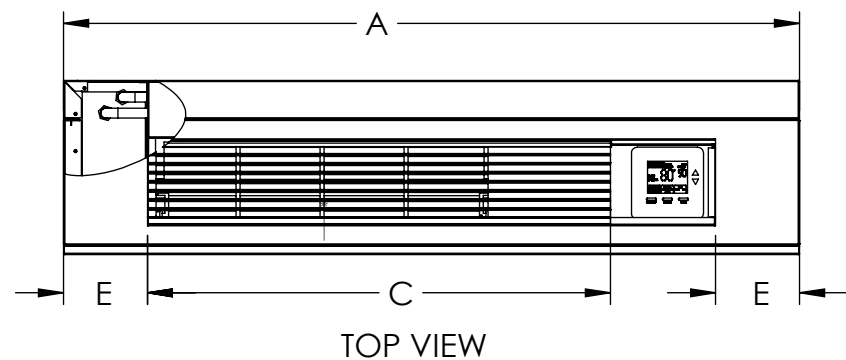

	A	B	C	D	E
CHPW09	46"	22"	29"	45"	5 1/2"
CHPW13	46"	22"	29"	45"	5 1/2"
CHPW16	54"	31"	38"	53"	5"
CHPW19	54"	31"	38"	53"	5"

NOTES:

1. DIMENSIONS ARE SHOWN IN INCHES.
2. ALL DIMENSIONS ARE  $\pm 1/4"$ .
3. UNITS IS SHIPPED WITH UNIVERSAL LEFT-HAND OR RIGHT HAND PIPING CAPABILITY.
4. SUPPLY AND RETURN PIPES HAVE NPT 1/2" THREADED MALE ADAPTER.

MATERIAL:	<b>ICE-AIR LLC.</b> 80 HARTFORD AVENUE MOUNT VERNON, NY 10553		
WEIGHT (LBS):			
FINISH:	TITLE: CONSOLE WATER SOURCE HEAT PUMP FLAT TOP UNIVERSAL PIPING		
UNLESS OTHERWISE SPECIFIED: DIMENSIONS ARE IN INCHES TOLERANCES: FRACTIONAL $\pm 1/32$ ANGULAR: MACH $\pm \circ$ BEND $\pm 1 \circ$ TWO PLACE DECIMAL $\pm .03$ THREE PLACE DECIMAL $\pm .015$	MODEL BY: VP	DATE: 05/29/09	DWG. NO.
	DRAWING BY: ZESHAN	DATE: 11/22/17	CHPW-FUP
SIZE <b>B</b>	SCALE: NONE DO NOT SCALE DRAWING	SHEET 1 OF 1	REV F

Third Angle Projection

**PROPRIETARY AND CONFIDENTIAL**  
 This drawing is the intellectual property of Ice Air, LLC and consists of confidential data belonging solely to Ice Air, LLC. The sharing of this data with you does not constitute a license to share this data with any third party, which is strictly prohibited without Ice Air's prior written consent.

## Ice Air LLC

### **MODEL "CHPW" SIZE 09-18 CONSOLE WATER SOURCE HEAT PUMP SPECIFICATIONS**

September 25, 2018

#### **General:**

Provide Ice Air "CHPW" Series Console Water Source Heat Pumps, as indicated on the Project plans. Equipment shall be delivered completely assembled and internally wired and shall meet the capacities and characteristics listed in the Equipment Schedule and the project Mechanical Specifications.

#### **Console Water Source Heat Pumps:**

Units shall operate within the entering water temperature range of 60° to 100°F. Equivalent units from other manufacturers can be proposed provided approval to bid is given 10 days prior to bid closing. All equipment listed in this section must be rated in accordance with American Refrigeration Institute / International Standards Organization (ARI / ISO) and Environmental Testing Laboratories for United States and Canada (ETL-US-C). The units shall have ETL-US-C labels. All units shall be factory tested under normal operating conditions. ***Units tested without water flow are not acceptable.***

#### **Basic Construction:**

Console Water Source Heat Pump unit shall consist of the Heat Pump Chassis, containing the water-to-air refrigerant system, the fan / motor assembly (air handling system), and unit mounted controls (optional wall mount controls available); integral universal (left-hand or right-hand) piping connections; painted sub base and painted room cabinet with integral grille and control access door.

Console units shall have one of the following Standard air flow and piping arrangements: Bottom Air Inlet/Right-hand Piping; Bottom Air Inlet/Left-hand piping; as shown on the Project plans

#### **Room Cabinet:**

The cabinet, wall mounting hardware and subbase shall be constructed of heavy gauge galvanized steel with a powder coat paint finish. Corrosion protection system shall meet the stringent 1000-hour salt spray test per ASTM B117. ***Unit corrosion protection must meet these requirements or unit(s) will not be accepted.*** Color will be Antique White. Both sides of the steel shall be painted for added protection. Additionally, the wall mounting hardware shall have welded corner bracing. The easily removable cabinet enclosure allows for easy service to the chassis, piping compartment and control compartment.

Cabinet shall contain an extruded aluminum clear anodized air discharge grille and matching control access door.

All interior surfaces of Cabinet shall be lined with 1/2 inch (12.7mm) thick fiberglass insulation. Insulation placement shall be designed in a manner that will eliminate any exposed edges to prevent the introduction of glass fibers into the air stream.

Standard insulation must meet NFPA Fire Hazard Classification requirements 25/50 per ASTM E84, UL 723, CAN/ULC S102-M88 and NFPA 90A requirements; air erosion and mold growth limits of UL-181; fungal resistance test per ASTM-C1071 and ASTM G21; and shall meet zero level bacteria growth per ASTM G22. ***Unit insulation must meet these requirements or unit(s) will not be accepted.***

Return Air Filter shall be 1" permanent cleanable type media for bottom return units.

*Option: The cabinet shall have a 30° sloped top with clear anodized extruded aluminum discharge grille including hinged control door. Cabinet shall have rounded edges on all exposed corners for safety and esthetic purposes.*

*Option: The unit cabinet shall be painted Arctic White or Antic White color.*

#### **Chassis:**

Heat Pump chassis shall be a self-contained assembly fabricated from 18-gauge galvanized steel, containing the sealed water-to-air refrigerant circuit, air handling system (fan and motor assembly), unit controls and piping and wiring connections.

#### **Fan and Motor Assembly:**

Fan and motor assembly shall be assembled on fan deck with quick electrical disconnecting means to provide and facilitate easy field servicing. The fan motor shall be multi-speed, permanently lubricated, PSC type, with internal thermal overload protection. The fan motor shall include a torsionally flexible motor mounting system or saddle mount system with resilient rings to inhibit vibration induced high noise levels associated with "hard wire belly band" motor mounting. The airflow rating of the unit shall be based on readings conducted with a wet coil and a clean air filter in place. ***Ratings based on a dry coil and / or no filter shall NOT be acceptable.***

#### **Refrigerant Circuit:**

All units shall contain a sealed refrigerant circuit employing R410A green refrigerant and including a high efficiency rotary compressor designed for heat pump operation, capillary tube refrigerant metering device, refrigerant-to-air heat exchanger, reversing valve, coaxial (tube in tube) refrigerant-to-water heat exchanger, and safety controls. Safety controls shall include high pressure switch, low pressure switch (loss of charge), water coil low temperature sensor, and air coil low temperature sensor. Access fittings shall be factory installed on high and low pressure refrigerant lines to facilitate field service. Activation of any safety device shall prevent compressor operation via a microprocessor lockout circuit.

Hermetic compressors shall be internally sprung. The compressor shall have a dual level vibration isolation system. The compressor will be mounted on vibration isolation grommets to a large heavy gauge compressor mounting tray plate, which is then isolated from the cabinet base with rubber grommets for maximized vibration attenuation. Compressor shall have thermal overload protection. Compressor shall be

located in an insulated compartment away from air stream to minimize sound transmission.

Refrigerant-to-air heat exchanger shall utilize enhanced corrugated lanced aluminum fins and rifled copper tube construction rated to withstand 600 PSIG (4136 kPa) refrigerant working pressure. Refrigerant-to-water heat exchangers shall be of copper inner water tube and steel refrigerant outer tube design, rated to withstand 600 PSIG (4136 kPa) working refrigerant pressure and 450 PSIG (3101 kPa) working water pressure. The refrigerant to water heat exchanger shall be “electro-coated” with a low cure epoxy material a minimum of 0.4 mils thick (0.4 – 1.5 mils range) on all surfaces.

Refrigerant metering shall be accomplished by thermostatic expansion valve or capillary tube. Expansion valves shall be dual port balanced types with external equalizer for optimum refrigerant metering. Reversing valve shall be four-way solenoid activated refrigerant valve, which shall default to heating mode should the solenoid fail to function. If the reversing valve solenoid defaults to cooling mode, an additional low temperature thermostat must be provided to prevent over-cooling an already cold room.

*Option: The unit will be supplied with internally factory mounted two-way water valve for variable speed pumping requirements. A factory-mounted temperature sensor shall be installed on the water piping to disable compressor operation in the event of water freezing in the piping system.*

*Option: The unit will be supplied with internally factory mounted automatic water flow regulators.*

#### **Piping:**

Provide integral universal ½” NPT piping connections. Units shall be shipped with plugs on piping connections, and field installer shall remove the plugs on the field piping side. Water piping shall terminate in the same location regardless of the connection and valve options.

*Option: factory mounted Motorized (Solenoid) Valve, Auto flow Valve and Custom Piping Configurations are available.*

#### **Drain Pan:**

The drain pan shall be constructed of galvanized steel with full powder coat paint application to further inhibit corrosion. Optional Stainless Steel drain pan is available. Drain pan shall be fully insulated. Drain outlet shall be located at pan as to allow complete and unobstructed drainage of condensate. Drain hose shall contain an integral P Trap. The unit will be supplied with either a solid-state electronic condensate overflow protection or mechanical overflow protection.

#### **Electrical:**

Unit controls shall be located under the hinged control door, located at the top of the Cabinet. Operating controls shall consist of switches to select “OFF”, “HEAT,” “COOL,” “AUTO”. Fan “AUTO” (fan cycles with compressor), Fan “ON” (continuous fan), Fan “LO” (low speed fan), Fan “MED” (Medium speed fan), and Fan “HI” (high speed fan). Temperature adjustment shall be accomplished via two push buttons, one labeled with an arrow up, and the other labeled with an arrow down. Controls shall include an LCD

or digital display for display of temperature and set point. **Units without an LCD or digital display shall not be accepted.**

A control box shall be located above the unit compressor compartment and shall contain operating controls as outlined in the paragraph above, 24VAC transformer, double-pole compressor relay, and solid-state controller for complete unit operation. Reversing valve and fan motor wiring shall be routed through this electronic controller. Units shall be name-plated for use with time delay fuses or HACR circuit breakers. A unit-mounted *digital* thermostat with a remote bulb measuring return air temperature shall control the compressor operation for heating and cooling. Control shall be equipped with a fan switch (provides options to cycle fan with compressor or provide continuous fan) and a fault indicator light.

Option: Provisions for remote thermostat (unit mounted is standard).

Option: Disconnect Switch, Non-Fused.

Option: 20A power plug/cord.

Option: 20A plug, cord, receptacle, disconnect switch, non-fused.

#### **Solid State Control System:**

Units shall have a solid-state control system. **Units utilizing electro-mechanical control shall not be acceptable.** The control system shall have the following features:

- a. Anti-short cycle time delay on compressor operation.
- b. Random start on power up mode.
- c. Low voltage protection.
- d. High voltage protection.
- e. Unit shutdown on high or low refrigerant pressures.
- f. Unit shutdown on low water temperature.
- g. Condensate overflow electronic protection.
- h. Option to reset unit at thermostat or disconnect.
- i. Automatic intelligent reset.
- j. Light emitting diode (LED) on circuit board to indicate high pressure, low pressure, low voltage, high voltage, low water/air temperature cut-out, condensate overflow, and control voltage status.
- k. The low-pressure switch shall not be monitored for the first 120 seconds after a compressor start command to prevent nuisance safety trips.
- l. 24V or line voltage output to cycle a motorized water valve or other device with compressor contactor.
- m. Water coil low temperature sensing.
- n. Air coil low temperature sensing.

NOTE: Units without the anti-short cycle, low voltage, high voltage, high refrigerant pressure, low pressure (loss of charge), air coil low temperature cut-out, water coil low temperature cut-out safety protections will not be acceptable.



**Warranty:**

Ice Air shall warranty equipment free from defects in material and workmanship for a period of 12 months from start up or 18 months from shipping (which ever occurs first).

Option: Extended 2-5year compressor warranty covers compressor for a total of 5 years.

Option: Extended 2-5year refrigeration circuit warranty covers coils, reversing valve, expansion valve and compressor.