

HORIZONTAL HYBRID WATER AIR CONDITIONER (HHW) CERTIFIED DRAWING

DWG. NO.
HHW-Series Submittal
REV. - 2.1

PROJECT	DATE	4/15/25	BY	ML	REVISIONS		
PURCHASER	P.O. #	QTY	DATE	BY	DESCRIPTION		
ARCHITECT	SHIPPING DATES						
ENGINEER							
HVAC CONTR.							
GEN. CONTR.							

DESIGNATION	MODEL NUMBER	QTY
TOTAL		

CUSTOM NOTES

1:

GENERAL NOTES

- 1: PROVIDE UNITS WITH R32 GREEN REFRIGERANT
- 2: PROVIDE 1" WASHABLE FILTERS
- 3: PROVIDE OVERFLOW CONDENSATE SWITCH
- 4: PROVIDE STANDARD UNIT-MOUNTED DIGITAL CONTROL BOARD
- 5: PROVIDE PAINTED ACOUSTICAL ACCESS DOOR FRONT PANEL
- 6: PROVIDE INTEGRAL TRAPPED CONDENSATE LINE RUN OUT

UNIT SPECIFICATIONS+ PERFORMANCE DATA

MODEL	8HHW09	8HHW12	8HHW15	8HHW18	8HHW24	8HHW30	8HHW36
COOLING CAPACITY (BTUH)	10,600	12,200	19,600	21,100	26,900	30,200	36,400
SENSIBLE CAPACITY (BTUH)	7,800	8,900	14,300	15,400	19,700	22,000	26,600
COOLING EER	16.4	14.5	17.4	16.8	16.6	16.2	16.4
FLOW RATE (GPM)	2.3	3.0	3.8	4.5	6.0	7.5	9.0
AIR FLOW (CFM)	300	400	500	600	800	1,000	1,200

TABLE 1

COOLING CAPACITY RATED @ 80.6°F DB, 66.2°F WB EAT; 86°F EWT

MODEL	8HHW09	8HHW12	8HHW15	8HHW18	8HHW24	8HHW30	8HHW36	
HEATING CAPACITY (BTUH)	EWT @ 120°F	10,500	16,900	21,000	25,500	28,000	31,200	37,400
	EWT @ 105°F	8,500	12,300	15,500	18,600	19,800	21,900	26,300
	EWT @ 95°F	6,300	9,200	12,000	15,800	16,700	17,800	21,300

TABLE 2

HEATING CAPACITY RATED @ 68°F EAT DB; @ 3GPM/TON

PHYSICAL DATA

MODEL	8HHW09	8HHW12	8HHW15	8HHW18	8HHW24	8HHW30	8HHW36
COMPRESSOR TYPE (1 PER)	ROTARY						
REFRIGERANT TYPE	R32						
REFRIGERANT FACTORY CHARGE (OZ)	18.7	19.0	28.2	30.0	33.2	35.3	42.3
BLOWER WHEEL SIZE (DIA X W)	6x6	7x7		8x8		9x7	
HOSES (IN)	36"						
STANDARD FILTER 1"	21.25x10.75		25.25x15.75		25.25x16.75		27.25x18.75
WATER CONNECTION (SUPPLY/RETURN)	1/2" F NPT				3/4" F NPT		
CONDENSATE CONNECTION (IN)	3/4" F NPT						
UNIT WEIGHT (LB)	130	140	180	220	280	300	310

TABLE 3

HORIZONTAL HYBRID WATER AIR CONDITIONER (HHW) CERIFIED DRAWING

DWG. NO.
HHW-Series Submittal
REV. - 2.1

PROJECT	DATE	4/15/25	BY	ML	REVISIONS		
PURCHASER	P.O. #	QTY	DATE	BY	DESCRIPTION		
ARCHITECT	SHIPPING DATES						
ENGINEER							
HVAC CONTR.							
GEN. CONTR.							

UNIT SPECIFICATIONS+

TABLE 4

MODEL	VOLTAGE/HZ-PHASE	COMPRESSOR RLA	COMPRESSOR LRA	FAN MOTOR FLA	TOTAL UNIT FLA	MINIMUM CIRCUIT AMPS	MAX FUSE /HACR
8HHW09	208-230/60-1	3.5	20	2.0	5.5	6.3	15
8HHW12	208-230/60-1	4.5	24	2.0	6.5	7.6	15
8HHW15	208-230/60-1	6.3	40	2.0	8.3	9.8	15
8HHW18	208-230/60-1	6.9	39	2.0	8.9	10.6	15
8HHW24	208-230/60-1	8.8	55	2.0	10.8	12.9	20
8HHW30	208-230/60-1	9.5	58	2.0	11.5	13.8	20
8HHW36	208-230/60-1	11.7	72	4.0	15.7	12.9	20

TABLE 5

AIR FLOW CORRECTION TABLE		70%	75%	80%	85%	90%	95%	100%	105%
Cooling Factors	% of Rated Air Flow								
	Total Capacity	0.92	0.93	0.95	0.96	0.97	0.99	1.00	1.02
	Sensible Capacity	0.80	0.83	0.87	0.90	0.93	0.97	1.00	1.04
	Power	0.97	0.97	0.98	0.99	0.99	1.00	1.00	1.01
Heating Factors	Heat Rejection	0.94	0.95	0.96	0.97	0.98	0.99	1.00	1.01
	Heating Capacity	0.94	0.95	0.96	0.97	0.98	0.99	1.00	1.01
	Power	1.08	1.06	1.05	1.04	1.02	1.01	1.00	0.99
	Heat Extraction	0.93	0.95	0.96	0.97	0.98	0.99	1.00	1.01

TABLE 6

		Cooling				
EAT WB (F°)		60	65	67	70	75
Total Capacity Factor		0.85	0.96	1.00	1.06	1.17
Sensible Capacity Factor EAT DB	70	0.85	0.62	0.52	-	-
	75	1.09	0.86	0.76	0.62	-
	80	1.33	1.09	1.00	0.86	0.63
	85	*	1.33	1.23	1.09	0.85
	90	*	*	1.48	1.34	1.10
Power Factor		1.00	1.00	1.00	1.00	1.01
Heat Rejection Factor		0.90	0.97	1.00	1.05	1.12

DB - dry bulb air temperature

WB - wet bulb air temperature

All temperatures are in F

*Sensible capacity equals total capacity

REVISIONS			
REV.	DESCRIPTION	BY	DATE
01			4/10/2013
A			10/20/2015
B	CHART DIMENSIONS CORRECTED		9/16/2016
C	SIZES 42-70 REMOVED	ML	4/17/2025

LEFT HAND RETURN, END DISCHARGE

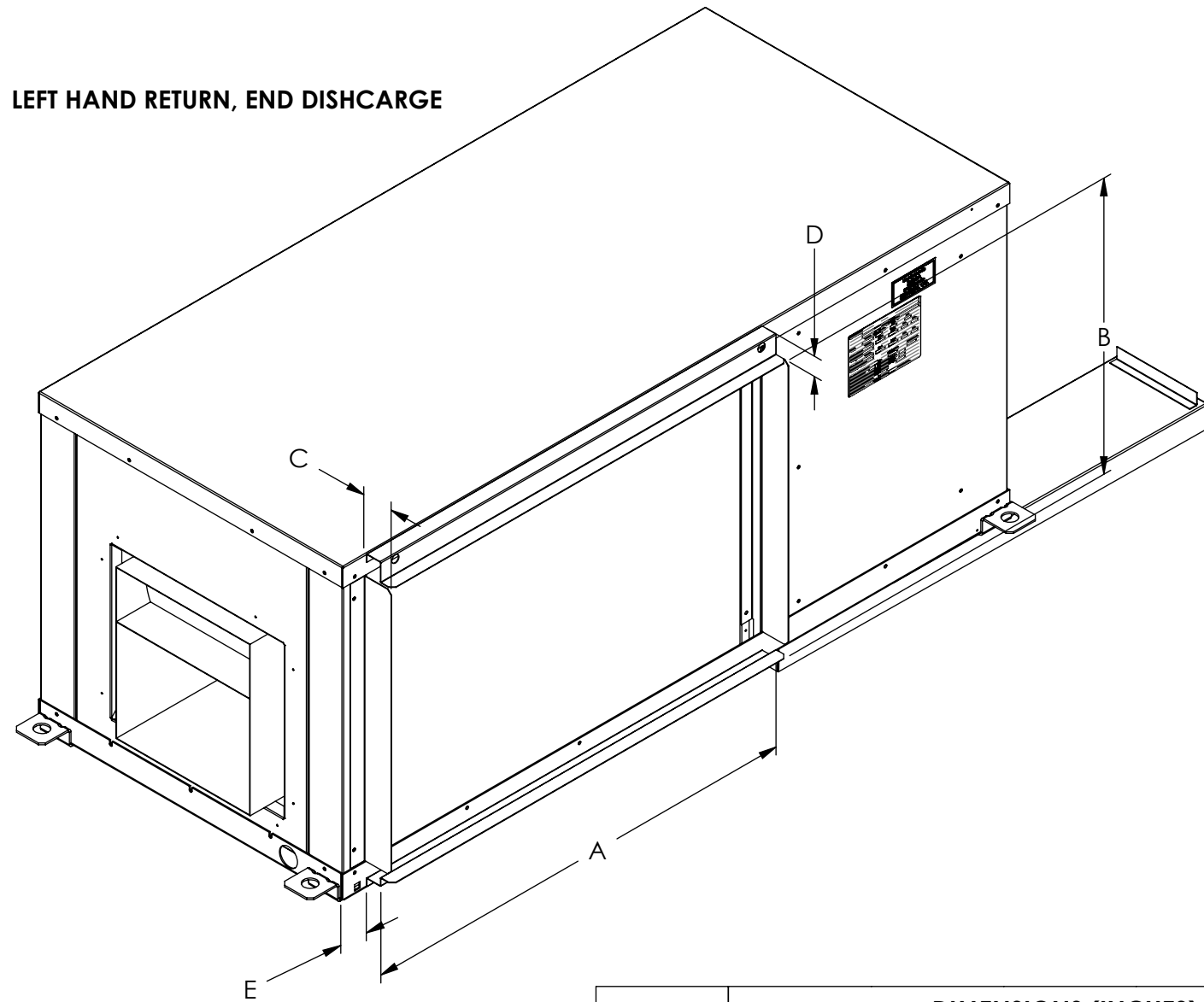

RIGHT HAND RETURN, END DISCHARGE

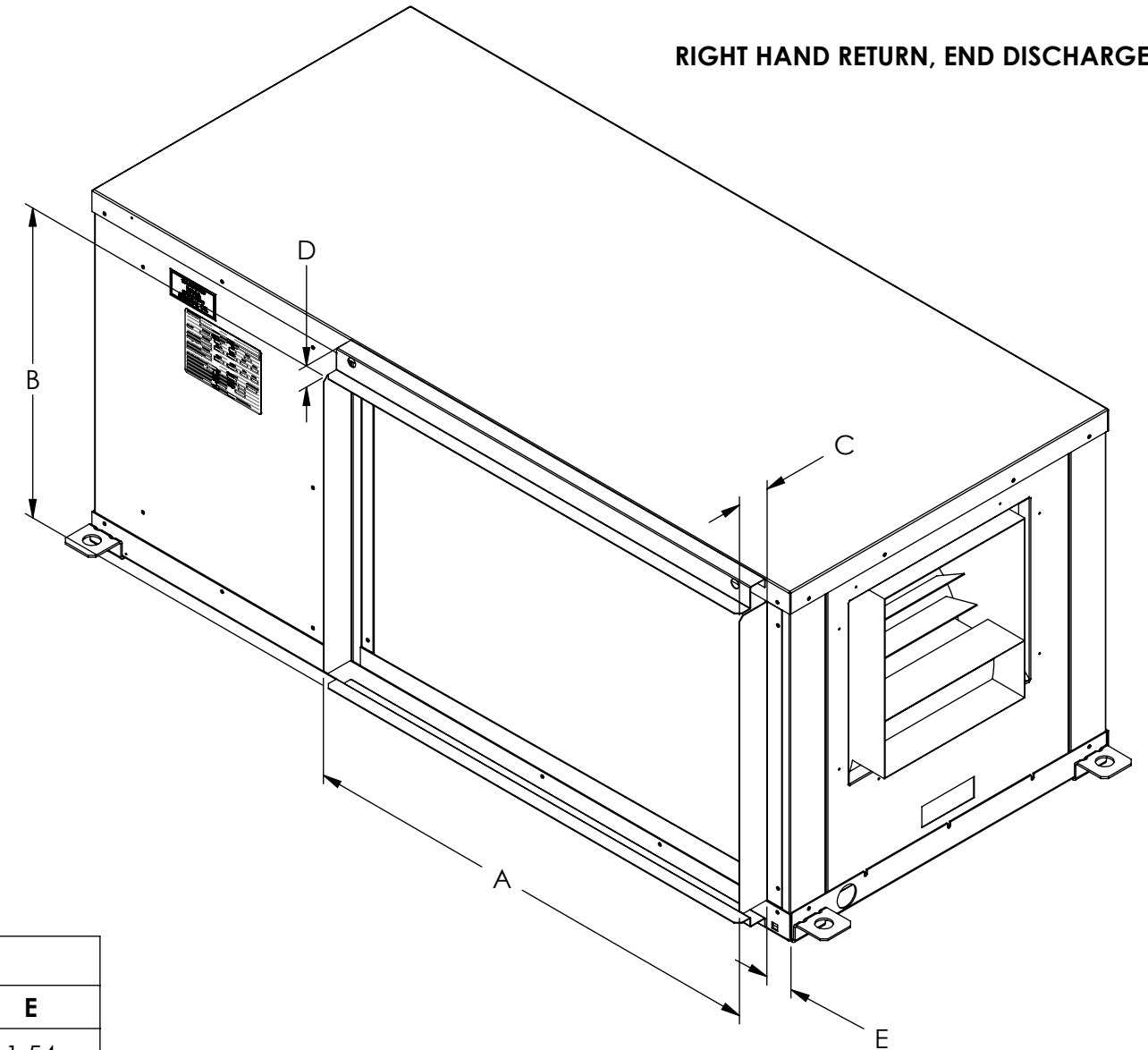

UNIT SIZE	DIMENSIONS (INCHES)				
	A	B	C	D	E
09/12	21.41	9.12	1.83	1.20	1.54
15/18	25.42	14.60	1.83	1.20	1.54
24/30	25.42	16.68	1.83	1.20	1.54
36	27.42	17.68	1.83	1.20	1.54

NOTE.
FILTER RACK/RETURN AIR DUCT COLLAR.

MATERIAL:	ICE-AIR LLC. 80 HARTFORD AVENUE MOUNT VERNON, NY 10553			
WEIGHT (LBS): 115.85				
FINISH: N/A	TITLE: HYBRID HORIZONTAL WATER SOURCE HEAT PUMP SUBMITTAL DRAWING	MODEL BY: VP	DATE: 07/15/10	DWG. NO.
UNLESS OTHERWISE SPECIFIED: DIMENSIONS ARE IN INCHES TOLERANCES: FRACTIONAL ± 1/32 ANGULAR: MACH ± ° BEND ± 1° TWO PLACE DECIMAL ± .03 THREE PLACE DECIMAL ± .015	DRAWING BY: ML	DATE: 04/17/25	HHW-Series (Dim. Draw)	
	SIZE B	SCALE: NONE DO NOT SCALE DRAWING	SHEET 1 OF 2	REV C

PROPRIETARY AND CONFIDENTIAL
 This drawing is the intellectual property of Ice Air, LLC and consists of confidential data belonging solely to Ice Air, LLC. The sharing of this data with you does not constitute a license to share this data with any third party, which is strictly prohibited without Ice Air's prior written consent.

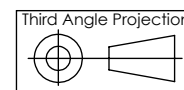

DIMENSIONAL DATA: END AND STRAIGHT DISCHARGE

PHYSICAL DATA

UNIT SIZE	09/12	15/18	24/30	36
OVERALL UNIT DIMENSIONS	20"Wx34"Lx12.00"H	20"Wx42"Lx17"H	20"Wx42"Lx18 1/4"H	21"Wx46"Lx20"H
WATER CONNECTIONS, FPT	1/2	1/2	3/4	3/4
CONDENSATE CONNECTION, FPT	3/4	3/4	3/4	3/4

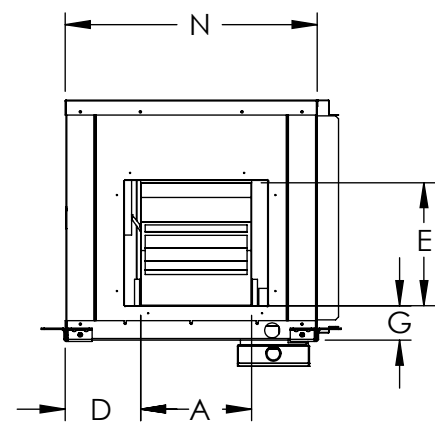

END DISCHARGE VIEW

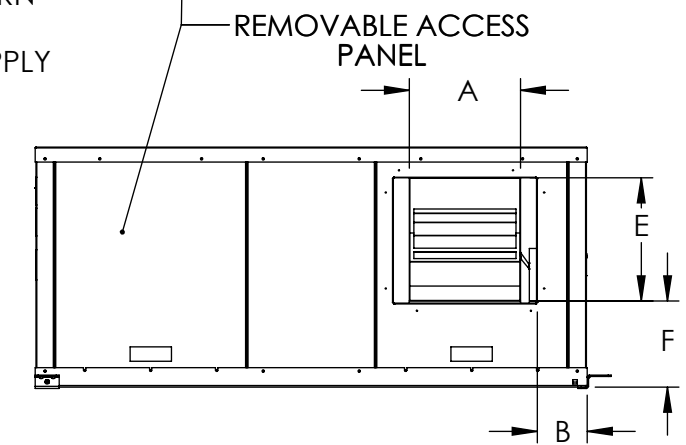
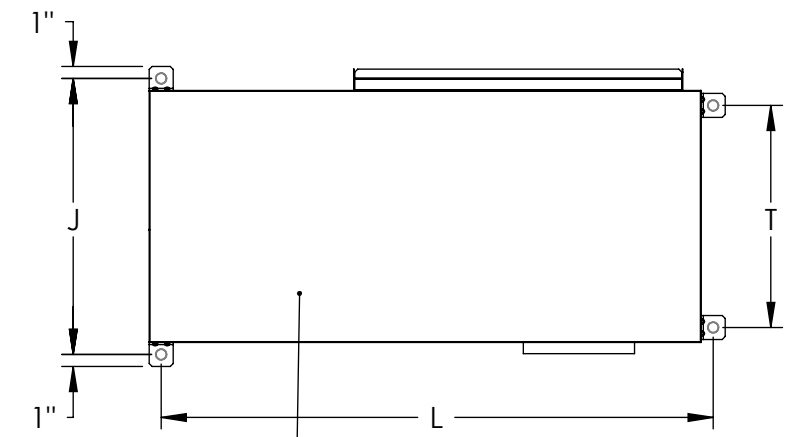
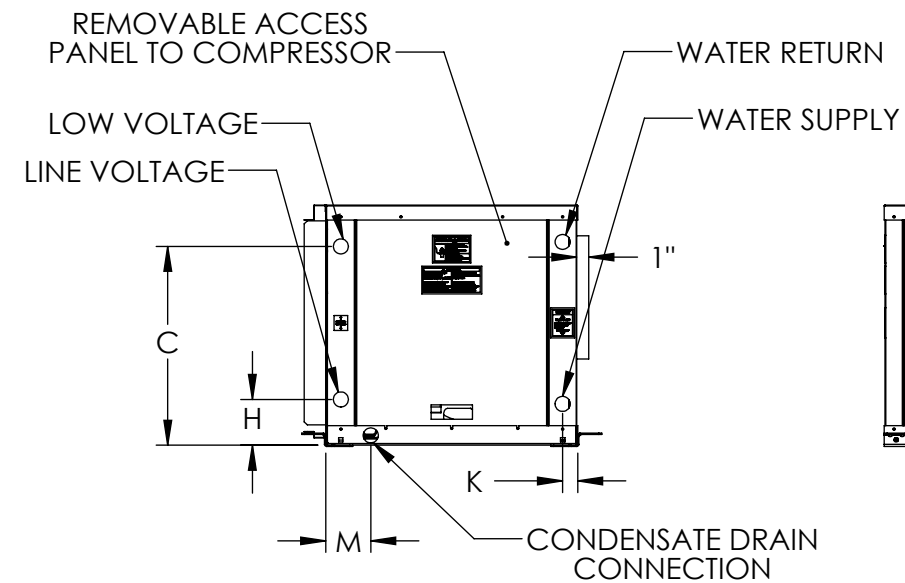
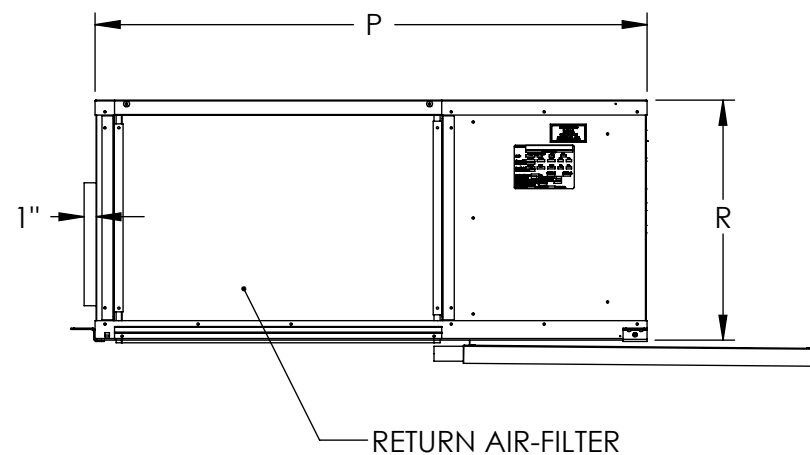

STRAIGHT DISCHARGE VIEW

DIMENSIONAL DATA (IN INCHES)

UNIT SIZE	DIMENSIONS															
	A	B	C	D	E	F	G	H	J	K	L	M	N	P	R	T
09	9.6	2.9	8.5	4.6	4.8	1.8	1.9	3.5	22	1.3	34	3.8	20	34	11.5	17.5
12	9.6	4.4	8.5	3.7	4.8	1.8	5.0	3.5	22	1.3	34	1.6	20	34	11.5	17.5
15/18	9.3	3.0	14.0	3.5	8.2	7.0	2.0	3.5	22	1.3	42	3.8	20	42	17	17.5
24/30	9.3	3.0	15.2	4.0	7.0	8.9	2.3	3.5	22	1.3	42	3.8	20	42	18.25	17.5
36	12.0	4.8	17.0	4.3	10.3	6.2	4.0	3.5	23	1.3	46	3.8	21	46	20	18.5

NOTE.

- RIGHT AND LEFT HAND RETURN DETERMINED BY FACING THE WATER CONNECTION SIDE OF THE UNIT.
- BLOWER HOUSING ASSEMBLY CONVERTS FROM STRAIGHT DISCHARGE TO END DISCHARGE.
- DIMENSIONS ARE APPROXIMATE.
- LEFT HAND RETURN SHOWN. RIGHT HAND RETURN OPTIONAL.

MATERIAL:	ICE-AIR LLC. 80 HARTFORD AVENUE MOUNT VERNON, NY 10553		
WEIGHT (LBS): 115.85	TITLE: HYBRID HORIZONTAL WATER SOURCE HEAT PUMP SUBMITTAL DRAWING		DWG. NO.
FINISH: N/A	MODEL BY: VP	DATE: 07/15/10	HHW-Series (Dim. Draw)
UNLESS OTHERWISE SPECIFIED: DIMENSIONS ARE IN INCHES TOLERANCES: FRACTIONAL ± 1/32 ANGULAR: MACH ± ° BEND ± 1° TWO PLACE DECIMAL ± .03 THREE PLACE DECIMAL ± .015	DRAWING BY: ML	DATE: 04/17/25	REV C
SIZE B	SCALE: NONE DO NOT SCALE DRAWING	SHEET 2 OF 2	

PROPRIETARY AND CONFIDENTIAL
This drawing is the intellectual property of Ice Air, LLC and consists of confidential data belonging solely to Ice Air, LLC. The sharing of this data with you does not constitute a license to share this data with any third party, which is strictly prohibited without Ice Air's prior written consent.

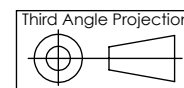

MODEL HHW SIZE 009-036
HYBRID WATER COOLED AIR CONDITIONER SPECIFICATIONS

General:

Furnish and install Ice Air HHW Horizontal 'Hybrid' Water Cooled Air Conditioners with Hydronic Heat, as indicated on the plans. Equipment shall be completely assembled, internally piped and wired. Capacities and characteristics shall be as listed in the schedule and in the specifications that follow.

Horizontal Hybrid Water Cooled Air Conditioner:

Units shall be supplied completely factory assembled and shall be designed to function with an entering water temperature (EWT) range from 60° to 110°F as standard. Extended range versions available as optional. All equipment listed in this section must be rated and certified in accordance with American Heating & Refrigeration Institute / International Standards Organization (ARI / ISO) for performance and Intertek for safety in the United States and Canada (ETL/C/US). All units shall be fully factory run tested under the normal operating conditions and water flow rates as described herein. Serial numbers will be recorded by factory and, upon request, furnished to Purchaser for ease of unit warranty status. *Units tested without water flow are not acceptable.*

Basic Unit Construction:

Horizontal Units shall have one of the following air flow arrangements: Left Inlet/Straight (Right) Discharge; Right Inlet/Straight (Left) Discharge; Left Inlet/Back Discharge; or Right Inlet/Back Discharge, as shown on the building mechanical plans. Units must have the ability to be field convertible from straight to back or back to straight discharge with no additional parts or unit structure modification. Horizontal units will have factory installed hanger brackets and be supplied with with separately packaged rubber isolation grommets.

Compressor section interior surfaces shall be lined with 1/2 inch (12.7mm) thick, dual density, 1-3/4 lb/ft³ (28 kg/m³) acoustic type glass fiber insulation. Air handling section interior surfaces shall be lined with 1/2 in (12.7mm) thick, single density, 1-3/4 lb/ft³ (28 kg/m³) coated fiber insulation for ease of cleaning. . Insulation placement shall be designed in a manner that will eliminate any exposed edges to prevent the introduction of glass fibers into the air stream.

Units shall be fabricated from heavy gauge galvanized steel. Interior condensate bearing surfaces shall additionally be coated with a powder coat paint finish

Standard cabinet panel insulation must meet NFPA 90A requirements, air erosion and mold growth limits of UL-181, stringent fungal resistance test per ASTM-C1071 and ASTM G21, and shall meet zero level bacteria growth per ASTM G22.

All horizontal units to have factory installed 1" discharge air duct collars, 1" filter rails and factory installed unit-mounting brackets. All units must have an insulated panel separating the fan compartment from the compressor compartment. Units with the compressor in the air stream are not acceptable. Units shall have a factory installed 1 inch wide filter bracket for filter

removal from either side. If required by the purchaser or building codes, the contractor shall purchase one spare set of filters and replace factory shipped filters on completion of start-up.

Cabinets shall have separate holes and knockouts for entrance of line voltage and low voltage control wiring. All factory-installed wiring passing through factory knockouts and openings shall be protected from sheet metal edges at openings by plastic ferrules. Supply and return water connections shall be copper NPT fittings, and shall be securely mounted flush to the cabinet corner post allowing for connection to a flexible hose without the use of a back-up wrench. All water connections and electrical knockouts must be in the compressor compartment corner post so as to not interfere with the serviceability of unit. Contractor shall be responsible for any extra costs involved in the installation of units that do not have this feature. Contractor must ensure that units can be easily accessed and removed for servicing and coordinate locations of electrical conduit and lights with the electrical contractor.

Option: The unit will be supplied with factory mounted two-way water valve for variable speed pumping requirements.

Option: The unit will be supplied with factory mounted automatic water flow regulators.

Fan and Motor Assembly:

Units shall have a direct-drive centrifugal fan. The fan motor shall be 3-speed, permanently lubricated, PSC type with internal thermal overload protection. The fan motor on small and medium size units (018-036) shall be isolated from the fan housing by a flexible motor mounting system with rubber type grommets to inhibit vibration. The fan and motor assembly must be capable of overcoming the external static pressures as shown on the schedule. Airflow / Static pressure rating of the unit shall be based on a dry coil and a clean filter in place. ***Ratings without filter, or on an ESP less than 0.25 in w.g. (6.35 mm w.g.) shall NOT be acceptable.***

Option: Provide EC (Electronically Commutated) Motors as required by Project Specifications and / or local Building Codes.

Hydronic Heating:

The refrigeration circuit shall not operate during heating mode. Heating coil shall be aluminum fin and copper tubing type rated to withstand 300 PSI working pressure. Heating coil shall be of sufficient size and tubing routing to supply specified heating capacity at 90°F – 120°F. Entering Water Temperatures (EWT).

Refrigerant Circuit:

All units shall contain an R-32 sealed refrigerant circuit including a high efficiency scroll or rotary compressor, a thermostatic expansion valve or capillary tube for refrigerant metering, an enhanced corrugated aluminum lanced fin and rifled copper tube refrigerant-to-air heat exchanger, reversing valve, coaxial (tube in tube) refrigerant-to-water heat exchanger, and safety controls including a high pressure switch, low pressure switch (loss of charge), water coil low temperature sensor, and air coil low temperature sensor. Access fittings shall be factory installed on high and low pressure refrigerant lines to facilitate field service. Activation of any safety device shall prevent compressor operation via a microprocessor lockout circuit. The lockout circuit shall be reset at the thermostat or at the contractor supplied disconnect switch. ***Units that cannot be reset at the thermostat shall not be acceptable.***

Hermetic compressors shall be internally sprung. The compressor shall have a dual level vibration isolation system. The compressor will be mounted on vibration isolation grommets to a large heavy gauge compressor mounting tray plate, which is then isolated from the cabinet base with rubber grommets for maximized vibration attenuation. Compressor shall have thermal overload protection. Compressor shall be located in an insulated compartment away from air stream to minimize sound transmission.

Refrigerant-to-air heat exchangers shall utilize enhanced corrugated lanced aluminum fins and rifled copper tube construction rated to withstand 600 PSIG refrigerant working pressure. Refrigerant-to-water heat exchangers shall be of copper inner water tube and steel refrigerant outer tube design, rated to withstand 600 PSIG working refrigerant pressure and 500 PSIG working water pressure. The refrigerant to water heat exchanger shall be “electro-coated” with a low cure epoxy material a minimum of 0.4 mils thick on all surfaces. The black colored coating shall provide a minimum of 1000 hours salt spray protection per ASTM B117-97 on all external steel and copper tubing.

Refrigerant metering shall be accomplished by thermostatic expansion valve or capillary tube. Expansion valves shall be dual port balanced types with external equalizer for optimum refrigerant metering.

Drain Pan:

The drain pan shall be constructed of power coated steel to inhibit corrosion. This corrosion protection system shall meet a 1000 hour salt spray test per ASTM B117. Drain pan shall be fully insulated. Drain outlet shall be located at pan as to allow complete and unobstructed drainage of condensate. The unit as standard will be supplied with solid-state electronic condensate overflow protection. ***Mechanical float switches will NOT be accepted.***

Horizontal units shall be furnished with a PVC slip condensate drain connection.

Electrical:

A control box shall be located within the unit compressor compartment and shall contain a 40VA transformer, 24 volt activated, 2 or 3 pole compressor contactor, terminal block for thermostat wiring and solid-state controller for complete unit operation. Reversing valve and fan motor wiring shall be routed through this electronic controller. Units shall be name-plated for use with time delay fuses or HACR circuit breakers. Unit controls shall be 24 Volt and provide heating or cooling as required by the remote thermostat / sensor.

Solid State Control System:

Units shall have a solid-state control system. ***Units utilizing internal electro-mechanical control shall not be acceptable.*** The control system shall interface with a heat pump type thermostat. The control system shall have the following features:

- a. Anti-short cycle time delay on compressor operation.
- b. Random start on power up mode.
- c. Low voltage protection.
- d. High voltage protection.
- e. Unit shutdown on high or low refrigerant pressures.
- f. Unit shutdown on low water temperature.
- g. Condensate overflow electronic protection.

- h. Automatic intelligent reset. Unit shall automatically reset the unit 5 minutes after trip if the fault has cleared. If a fault occurs 3 times sequentially without thermostat meeting temperature, then lockout requiring manual reset will occur.
- i. Ability to diable time delays for servicing.
- j. Light emitting diode (LED) on circuit board to indicate high pressure, low pressure, low voltage, high voltage, low water/air temperature cut-out, condensate overflow, and control voltage status.
- k. The low-pressure switch shall not be monitored for the first 120 seconds after a compressor start command to prevent nuisance safety trips.
- l. 24V output to cycle a motorized water valve or other device with compressor contactor.
- m. Water coil low temperature sensing (selectable for water or anti-freeze).
- n. Air coil low temperature sensing.

NOTE: Units not providing the 8 safety protections of anti-short cycle, low voltage, high voltage, high refrigerant pressure, low pressure (loss of charge), air coil low temperature cut-out, water coil low temperature cut-out, and condensate overflow protections will not be accepted.

Warranty:

Ice Air shall warranty equipment for a period of 12 months from start up or 18 months from shipping (which ever occurs first).

FIELD INSTALLED OPTIONS

Hose Kits (required for field water connections):

Water connections between chassis and the cabinet shall be accomplished via a hose kit surrounded by a stainless-steel braid. Hose kit shall have brass fittings with stainless-steel ferrules. Hose ends shall be solid External NPT which connects to mating fitting on cabinet shut off ball valve(s), and Internal NPSM (National Pipe Straight Mechanical) swivel end with fiber or EPDM washer which connects to mating threaded end connection on chassis. This hose kit accessory is required for each cabinet.

Valves:

The following valves are available and will be shipped loose:

- a. Ball valve; bronze material, standard port full flow design, IPT connections.
- b. Ball valve with memory stop and PT Port; standard port full flow design, IPT connections.
- c. “Y” strainer with cap; bronze material, IPT connections.
- d. Motorized water valve; slow acting, 24v, IPT connections.

For factory-piped valve and piping kits, consult your Sales Agent.

Thermostats:

The thermostat shall be an Ice Air electronic type thermostat as selected below with the described features:

- a. Single Stage Standard Manual Changeover

- Thermostat shall be a single-stage, vertical mount, manual changeover with HEAT-OFF-COOL system switch and fan ON-AUTO switch. Thermostat shall have a mechanical temperature indicator and set point indication. Thermostat shall only require 4 wires for connection. Mercury bulb thermostats are not acceptable.
- b. Single Stage Digital Manual Changeover with Two-Speed Fan Control
Thermostat shall be a single-stage, digital, manual changeover with HEAT-OFF-COOL system switch, fan ON-AUTO switch, and fan LO-HI switch. Thermostat shall have an LCD display with temperature and set-point(s) in °F or °C. The Thermostat shall provide permanent memory of set-point(s) without batteries. A fault LED shall be provided to display specific fault condition. Thermostat shall come standard with remote temperature sensor, but may be operated with internal sensor if desired via installation of a jumper.
 - c. Single Stage Digital Auto or Manual Changeover
Thermostat shall be a single-stage, digital, auto or manual changeover with HEAT-OFF-COOL-AUTO system switch and fan ON-AUTO switch. Thermostat shall have an LCD display with temperature and set-point(s) in °F or °C. The Thermostat shall provide permanent memory of set-point(s) without batteries. A fault LED shall be provided to display specific fault condition. Thermostat shall provide temperature display offset for custom applications.
 - d. Single Stage Digital Automatic Changeover with Two-Speed Fan Control
Thermostat shall be a single-stage, digital, auto or manual changeover with HEAT-OFF-COOL-AUTO system switch, fan ON-AUTO switch, and fan LO-HI switch. Thermostat shall have an LCD display with temperature and set-point(s) in °F or °C. The Thermostat shall provide permanent memory of set-point(s) without batteries. A fault LED shall be provided to display specific fault condition. Thermostat shall come standard with remote temperature sensor, but may be operated with internal sensor if desired via installation of a jumper..
 - e. Single Stage Manual Changeover Programmable 5/2 Day
Thermostat shall be 5 day/2 day programmable (with up to 4 set points per day), single stage (1H/1C), and manual changeover with HEAT-OFF-COOL system settings and fan ON-AUTO settings. Thermostat shall have an LCD display with temperature, set-point(s), mode, and status indication. The temperature indication shall be selectable for °F or °C. The thermostat shall provide permanent memory of set-point(s) without batteries. Thermostat shall provide convenient override feature to temporarily change set point.