

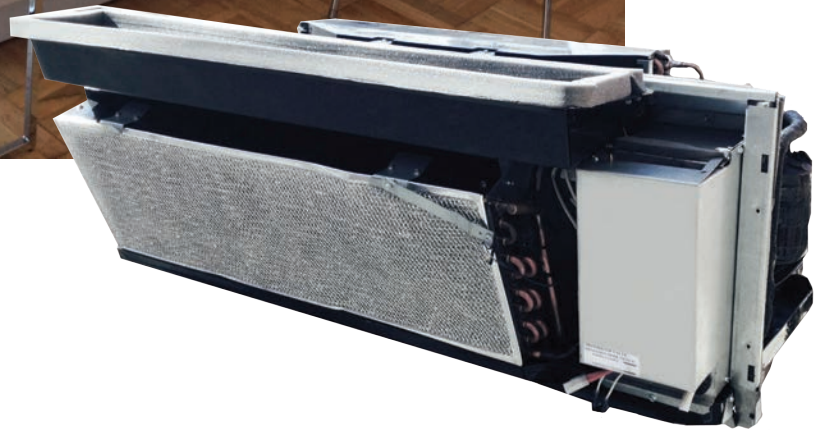

OPERATING & MAINTENANCE MANUAL

Packaged Terminal Air Conditioner (PTAC)

Model: RSAN



World Class Comfort.



OPERATING & MAINTENANCE MANUAL – PACKAGED TERMINAL AIR CONDITIONER (PTAC) – R5AN

WELCOME

Congratulations on your selection of ICE AIR Packaged Terminal Air Conditioners (PTACs) for your comfort conditioning requirements. PTAC units are thru-wall combination cooling and heating units, which provide an efficient, room-by-room source for comfort conditioning of your living environment.

ICE AIR PTAC units are built to a high standard of quality and reliability, employing commercial grade components and heavy duty, galvanized sheet metal casings. With proper maintenance and usage, ICE AIR PTACs should provide many years of efficient, quiet and trouble-free comfort.

To enhance the use of your ICE AIR equipment, you will want to read and carefully follow all of the instructions contained in this Operating & Maintenance Manual. We recommend that you pay special attention to the Safety & Operation information section at the beginning of this Manual, and to the various safety advisories throughout this Manual.

Please retain this manual for your future reference. We suggest that you retain it with other important documents and product manuals. The information contained within this manual, unless noted herein, applies to all ICE AIR PTAC models. If your unit has optional features, they will be explained in a separate instruction sheet specific to that option.

On behalf of ICE AIR, and our network of distributors and dealers, we are happy to welcome you to our base of satisfied customers!

SAFETY & OPERATION

FOR SAFE AND OPTIMAL ENJOYMENT OF YOUR ICE AIR PTAC UNIT, PLEASE READ THE FOLLOWING CONSUMER SAFETY AND OPERATING NOTES CAREFULLY BEFORE OPERATING YOUR EQUIPMENT!

We recommend that you record the following information about your ICE AIR PTAC products:

LOCATION	MODEL #	SERIAL #
Living Room		
Master Bedroom		
Bedroom		
Dining Room		

- This unit **MUST** be serviced only by professionally trained, qualified technicians. Do **NOT** attempt to maintain or service this unit on your own – severe injury and death can occur from electric shock, moving parts, and other hazards.
- Our ICE AIR units must each be wired on an individual, dedicated electrical circuit with the correct voltage and proper amperage (capacity) to match the unit nameplate requirements.
- Each unit’s electric circuit must have a proper overcurrent protection device, employing an approved circuit breaker or fuse of the proper rating under NEMA and local building codes.
- Every unit contains refrigerant within a sealed and pressurized refrigerant system. This system must not be opened or tampered with and any refrigeration system repairs **MUST** be carried out by trained technicians. Refrigerant must be properly handled and recycled per EPA regulations and guidelines.

Your ICE AIR unit must be properly installed and commissioned to operate correctly. Improper unit installation, adjustment or commissioning, and / or improper heating system installation and connection can lead to equipment malfunction and hazardous operating conditions, and may void your warranty. If you have any doubt about the proper installation of your PTAC unit, please contact your property manager at once to have a qualified technician inspect the equipment.

OPERATING & MAINTENANCE MANUAL – PACKAGED TERMINAL AIR CONDITIONER (PTAC) – RSAN

Do NOT operate the equipment when in doubt – have it inspected first!

IMPORTANT NOTE: It is not the intent of this maintenance manual to correct any installation deficiencies. If you have any doubt about the proper initial installation (or reinstallation after servicing) of your PTAC unit(s)– noisy or inefficient unit operation, frayed or damaged electrical connections, improper unit appearance, etc. – please contact a trained servicer or building maintenance staff immediately.

THE FOLLOWING PHYSICAL CONDITIONS MUST BE MAINTAINED FOR PROPER UNIT OPERATION:

Unobstructed air flow into and out of the unit room enclosure (cabinet). Therefore:

- Do not place furniture, rugs or objects directly in front of, underneath or against the unit cabinet front.
- Do not place plants, fabrics or objects on top of or blocking the enclosure discharge grille (at the cabinet top).
- Do not block the top of the cabinet with drapes or curtains. To ensure proper cooling and heating, drapes and curtains should be opened or positioned so that the air discharge from the unit does not flow behind these window treatments.
- Have the unit filter properly cleaned and serviced to prevent air blockage from dirt and dust within the filter media.

Proper installation and operating environment must be maintained. Therefore:

- Do not operate the unit in corrosive environments such as chemical plants, refineries or salt spray areas.
- Operate only with proper electrical service and protective circuit breakers or fuses in place.
- Operate only with all chassis and enclosure sheet metal parts in place and properly installed.
- In areas of high concentrations of dirt, dust, pet dander or pollutants, clean the filter often (at least monthly). If these or similar pollutants are present outdoors, have the unit condenser coil cleaned by trained service personnel.
- Do not clean the unit with any solvents or cleaning solutions that may damage the equipment (see maintenance instructions for proper cleaning protocols).
- Understand and follow the unit operating instructions below before using your PTAC equipment.
- Operate only with proper electrical service and protective circuit breakers or fuses in place.
- Operate only with all chassis and enclosure sheet metal parts in place and properly installed.

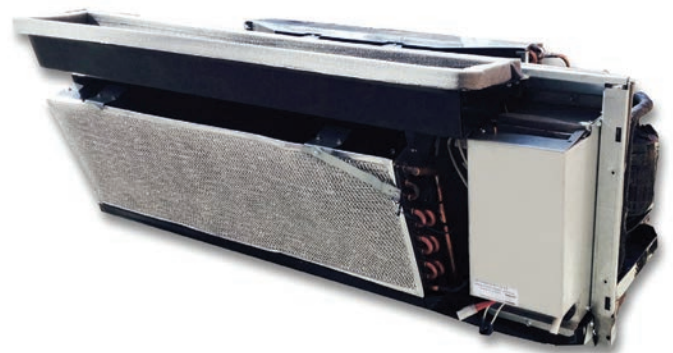

RSAN EXPLODED VIEW

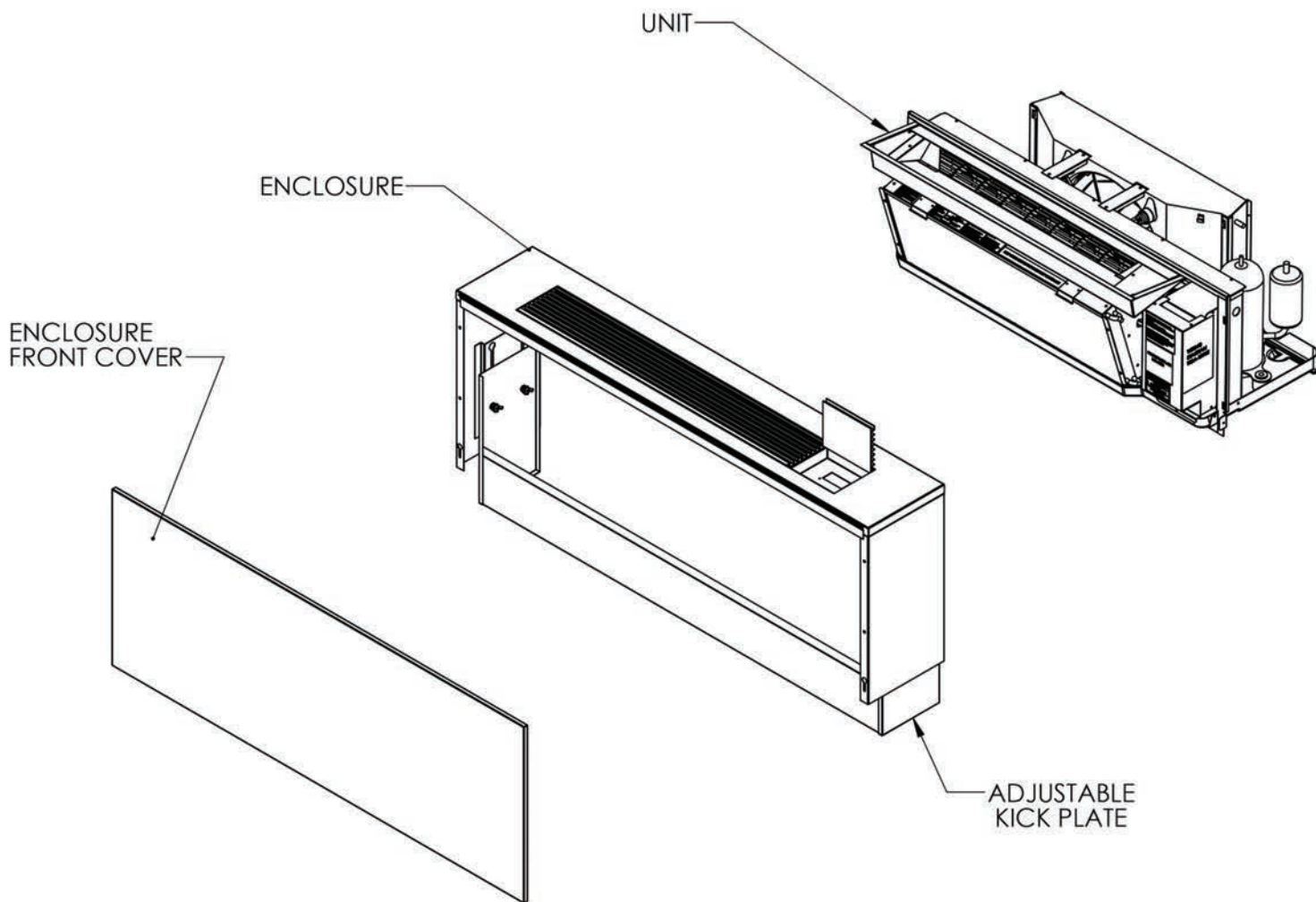

OPERATING & MAINTENANCE MANUAL – PACKAGED TERMINAL AIR CONDITIONER (PTAC) – RSN

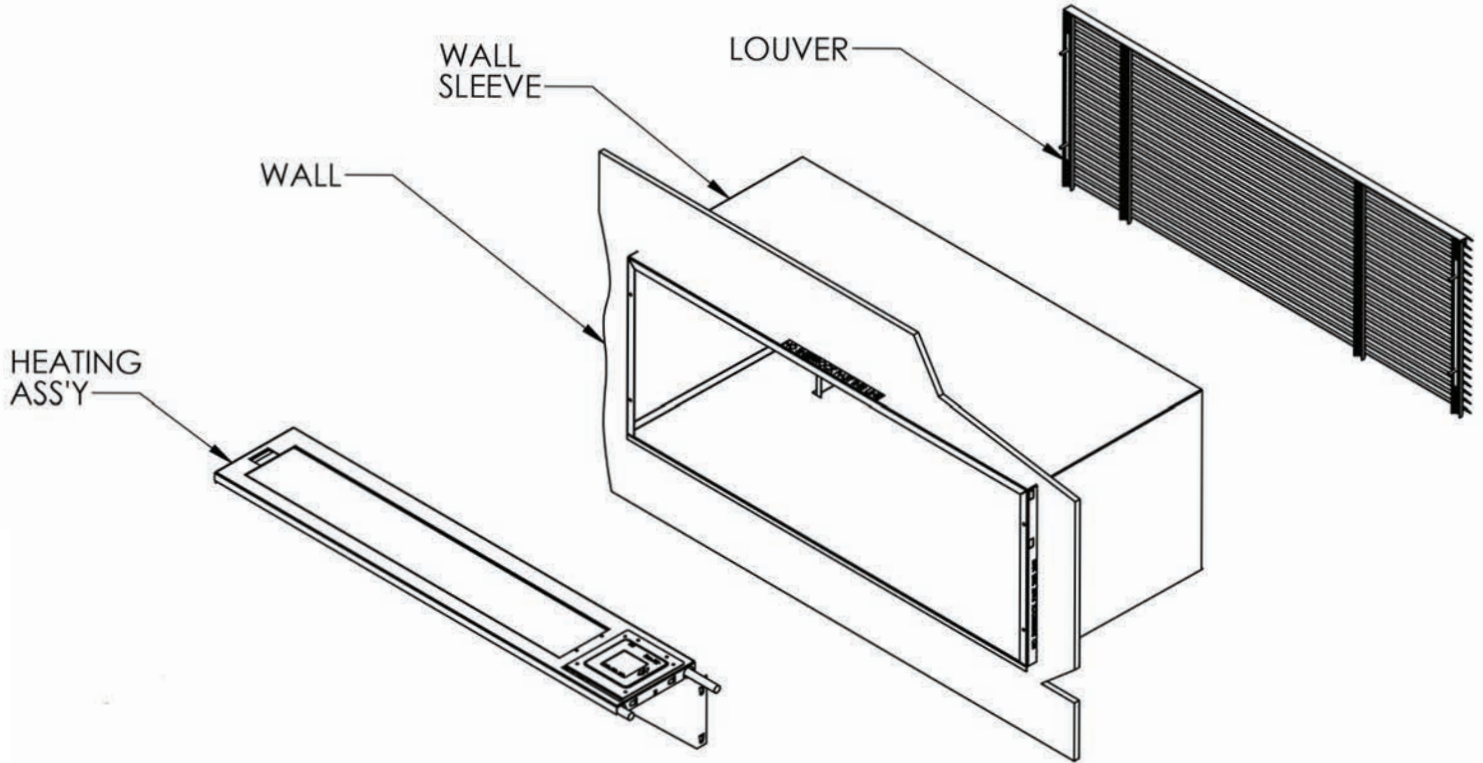

DIMENSIONAL DRAWING

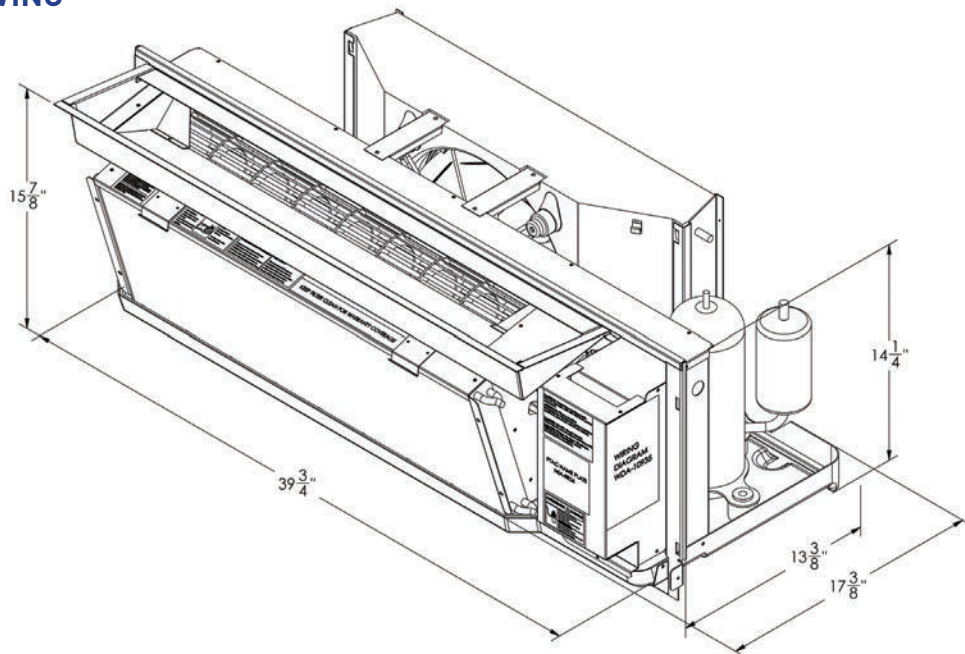

OPERATING & MAINTENANCE MANUAL – PACKAGED TERMINAL AIR CONDITIONER (PTAC) – R5AN

CONTROLS

All standard ICE AIR PTAC units are equipped with digital controls. The standard controls are located under the Air Discharge Grille at the top of the room cabinet. Lift the Access Door, located at the right side of the Air Discharge Grille, to access the control panel.

STANDARD DIGITAL TOUCHPAD



1. YOUR PTAC'S TECHNICAL SPECIFICATIONS INCLUDE:

- Set-point Temperature Range..... 61-90°F
- Display resolution.....1°F
- Operating Relative Humidity.....40-98%
- Fan Speed.....High, Medium or Low
- Operating Modes..... Cooling, Heating and Fan

2. BASIC OPERATIONS

- **Display:** The thermostat panel displays the actual temperature in the room. In order to view the setpoint temperature, press the UP or DOWN button once.
- **Power:** Press the ON/OFF button to turn the thermostat on or off. Upon the next power up, the control will stay in the same operating mode as it was prior to the last power off.

- **Temperature Setting:** To set the desired temperature, press the UP/DOWN arrow buttons to adjust setting until the desired temperature set-point is reached.
- **Fan Speed:** Press the FAN button to select high, medium, or low fan speed.
- **Operating Modes:** Press the MODE button to select between Cooling, Heating and Fan modes.

3. OPERATING MODES

- **Cooling Mode:** Under cooling mode, the user can select a specific fan speed and temperature set-point.
- **Heating Mode:** Under heating mode, the user can select a specific fan speed and temperature set-point.
- **Fan Mode:** Under the fan mode, the user can select a specific fan speed.

4. FEATURES AND FUNCTIONS

- **Timer Function:** When the unit is off, the timer can be set between 1 to 24 hours for delayed start. When the unit is on, the timer can be set between 1 to 24 hours for delayed stop.
- **Sleep Function:** In the cooling mode, enabling the sleep feature will increase the temperature set-point by 2°F every hour for the first two hours, and then maintain the new set temperature point. In the heating mode, enabling the sleep feature will decrease the temperature set-point by 2°F every hour for the first two hours, and then maintain the new temperature set-point.
- **Data Back-Up:** In the event of a power failure, the operating mode, temperature set-point and fan speed will be saved. Upon the next power up, the unit will return to the saved mode by the user prior to the power failure.

5. ERROR CODES

	DESCRIPTION	TROUBLESHOOTING
E4	LOW REFRIGERANT CHARGE	Low charge, dirty filter, or dirty evaporator coil
E6	SYSTEM HIGH PRESSURE PROTECTION	Condenser fan failure, dirty condenser coil, or capillary tube blockage
E8	INDOOR COIL FREEZE PROTECTION	Dirty filter, dirty evaporator coil, or fan motor failure
E9	COMMUNICATION ERROR	Faulty wiring from touchpad to board or faulty board

DO NOT OPERATE ANY EQUIPMENT THAT DOES NOT APPEAR TO BE FUNCTIONING PROPERLY!

LCD PROGRAMMABLE THERMOSTAT



FEATURE LIST

- Operates on 2 stage Heat and 2 stage Cool
- 7 programs (Mo, Tu, We, Th, Fr, Sa, Su) or 5-2 programs (Mo-Fr, Sa-Su)
- 4 Separate Time and Temperature Settings for each program
- Heat and Cool set-points for each program
- EPROM stores heat and cool program settings
- Temporary Program Override
- Permanent Program Override
- Compressor Short Cycle Protection
- LCD Backlighting
- Low Temperature Protection

USER INTERFACE

SYMBOL	PRESS	HOLD
▲	UP/Override mode	UP/Permanent Override mode
▼	Down/Override mode	Down/Permanent Override mode
ON/OFF	ON/OFF	-----
MODE	Set operation mode	Internal Setting
FAN	Set fan speed/Confirm	-----

OPERATING & MAINTENANCE MANUAL – PACKAGED TERMINAL AIR CONDITIONER (PTAC) – R5AN

PUSH BUTTONS

Operation

Normal Mode

1. Press [ON/OFF] to turn on thermostat.
2. Press [Mode] to change the system mode.
3. There are three operation modes for Cool Mode, Heat Mode, Auto Mode.

Cool Mode

- To activate cooling mode, press the mode button until COOL displays.
- Press up/down arrow keys to your desired temperature.
- Compressor will cycle when temperature reaches the set-point. After compressor stops, allow at least 3 minutes before restarting (this applies only if you have manually turned the unit off or reset the thermostat – during normal running conditions, the unit will automatically allow for the required restart delay).

The temperature reading that is on constant display is the ambient room temperature.

Heat Mode

- To activate heating mode, press the Mode button until HEAT displays.
- Press up/down arrow keys to your desired temperature.
- The unit will cycle until the set temperature is achieved and then will continuously cycle to maintain the set temperature.

The temperature reading that is on constant display is the ambient room temperature.

Auto Mode

- To activate auto mode, press the mode button until AUTO displays.
- Press up/down arrow keys to set desired heat temperature.
- Wait 5 seconds for cool to appear.
- Press up/down arrow keys to set desired cool temperature.

- The unit will automatically cycle between heat and cool modes if unit exceeds desired set points. The temperature reading that is on constant display is the ambient room temperature.

Internal Setting

Enter internal setting mode by pressing and holding [Mode] key for 5 seconds

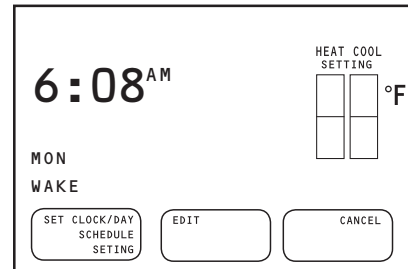

Time Setting

Set Clock/Day is flashing

1. Press [Mode] key to select Edit "Clock/Day".
2. Use [Up] and [Down] keys to adjust hours (12 hr).
3. Press [Mode] to select minutes.
4. Use [Up] and [Down] keys to adjust minutes.
5. Press [Mode] to select days.
6. Use [Up] and [Down] keys to adjust days
Press [Fan] when complete.

Daily Programming

Press [On/Off] to select Schedule (Schedule is flashing)

1. Press [Mode] key to select Edit "Set Schedule."
2. Use [Up] and [Down] to select Day.
3. Press [Mode] to edit time.
4. Use [Up] and [Down] to select Time.
(Adjustable in 10 minute increments)
5. Press [Mode] to edit heat setting.
6. Use [Up] and [Down] to select temperature.
7. Press [Mode] to edit cool setting.
8. Use [Up] and [Down] to select temperature.
9. Press [Mode] to set next time frame.
10. Follow the screen, and repeat steps 2 through 9 to adjust 7 day schedule programming.
11. Press [Fan] when complete.

OPERATING & MAINTENANCE MANUAL – PACKAGED TERMINAL AIR CONDITIONER (PTAC) – RSAN

Below is the default program:

	EVENT	TIME	HEAT	COOL
MON-FRI	WAKE	6:00 AM	70° F (21° C)	78° F (26° C)
	LEAVE	8:00 AM	62° F (17° C)	85° F (29.5° C)
	RETURN	6:00 PM	70° F (21° C)	78° F (26° C)
	SLEEP	10:00 PM	62° F (17° C)	82° F (28° C)
SAT-SUN	WAKE	6:00 AM	70° F (21° C)	78° F (28° C)
	LEAVE	10:00 AM	62° F (17° C)	85° F (29.5° C)
	RETURN	6:00 PM	70° F (21° C)	78° F (26° C)
	SLEEP	11:00 PM	62° F (17° C)	82° F (28° C)

The default selection is 5-2 day program.

Changing Program Schedule and Temperature Limits

Press [On/Off] twice to select Settings

(Settings is flashing)

1. Press [Mode] key to select Edit “Settings.”
2. Use [Up] and [Down] to select 7 Day or 5-2 Day.
3. Press [Mode] to edit Heat Temperature Limit.
4. Use [Up] and [Down] to set temperature.
Default internal setting: Heat limit 90°F
5. Press [Mode] to edit Cool Temperature Limit.
6. Use [Up] and [Down] to set temperature.
Default internal setting: Cool limit 60°F
7. Press [Fan] when complete.
The cool limit setting should be at least 4°F higher than the heat limit setting.
 - The cool limit setting is 55°F to 95°F
 - The heat limit setting is 51°F to 91°F

Exit Internal Setting and Return to Normal Mode

1. Press [Fan] to confirm and return to normal mode
2. If no key is pressed for 15 seconds, it will return to normal mode automatically

Temporary Program Override

1. When thermostat is ON, the program set-point can be temporarily override by pressing [UP] or [DOWN]. “OVERRIDE” icon will turn on. Press [UP] or [Down] to select the set-point
2. In Heat mode, Heat set-point can be adjusted
3. In Cool mode, Cool set-point can be adjusted
4. In Auto mode, Heat set-point will be set first and press [UP] or [DOWN] to set the Heat set-point. Press [Fan] to confirm the Heat set point. Cool set-point will be set second and press [UP] or [DOWN] to set the Cool set-point. Press [Fan] to confirm the Cool set-point.
5. Temporary Override will be cancelled if user changes the operation mode or the unit enters the next program time session.

Permanent Override

1. Holding [UP] and [Down] key for 2 seconds to enter Permanent Override mode.
Permanent Override icon will turn on.
2. In Heat mode, Heat set-point can be adjusted.
3. In Cool mode, Cool set-point can be adjusted.
4. In Auto mode, Heat set-point will be set first and press [UP] or [DOWN] to set the Heat set-point. Press [Fan] to confirm the Heat set-point. Cool set-point will be set second and press [UP] or [DOWN] to set the Cool set-point.
5. Permanent Override will be cancelled if user changes the operation mode or turns off the unit.
6. Hold [Fan] key 5 seconds to cancel the permanent override mode.

Operating Specifications

- Temperature measurement
°C ~ 40°C / 32°F ~ 99°F
- Accuracy: ±0.5°C/ 1°F
- Voltage: 18-30VAC
- Temperature Controllable range:
5°C~35°C / 55°F ~ 95°F
- Resolution: 0.5°C / 1°F
- Operating temperature:
0 – 50 °C / 32 – 122 °F
- Storage temperature:
5 – 50 °C/ 23 – 122 °F

OPERATING & MAINTENANCE MANUAL – PACKAGED TERMINAL AIR CONDITIONER (PTAC) – RSN

MAINTENANCE OVERVIEW

Your ICE AIR PTAC Unit is designed to provide you with many years of efficient, trouble-free comfort conditioning service. To ensure equipment longevity and efficiency, please make sure that the following simple maintenance procedures are followed. This manual assumes that your PTAC unit has been installed by a qualified installation professional, and is operating properly prior to maintenance service.

Have your unit periodically inspected by a properly trained service professional or building maintenance staff person. The unit should be checked for the safe and proper functioning of all of its systems at least once a year. The following recommended maintenance procedures should be carried out only by trained personnel with strict adherence to the safety guidelines outlined at the beginning of this manual. These procedures **MUST** be followed to ensure your safety and the safety of the person maintaining the equipment!

It is recommended that you clean the indoor air filter after every 350 to 400 hours of unit operation – more frequently if the unit is running in an environment of high dust, pet dander or other pollutants in the indoor atmosphere.

Clean the condenser coil at least once a year, more frequently in an outdoor environment with high levels of pollution – including automobile traffic, smog or soot, etc. This procedure is critical to proper unit function and longevity. Clogged or dirty condenser coils will cause unit failure and may void any warranty coverage for the unit refrigeration system.

Check the unit condensate drain pan and drain hoses annually to ensure proper condensate drainage. If any foreign matter build-up in the drain pan is found, clean the drain pan and drain hoses – frequency of cleaning depends on the level of dirt and pollutants that may be present in the indoor environment.

Check and clean (if necessary) the unit evaporator coil annually.

Check unit line cord (power connection) for any fraying or deterioration of the plug and cord.

With these simple maintenance procedures carried out on a proper maintenance schedule, your unit should provide many years of trouble-free service. The procedures are covered in greater detail on the following pages, and should be implemented by trained personnel, but there are certain items that you, the apartment owner or tenant, can do to ensure proper unit function:

- Keep the area around your PTAC unit clear of objects that may block air flow into the unit – furniture, carpets and rugs, etc. may restrict air movement.
- Keep the top of your PTAC cabinet free of objects that may block air flow out of the unit – plants, paperwork and books, etc. should not be placed on or above the discharge grille area.
- Keep drapes, blinds and other window treatments clear of the air discharge area – any blockage of discharge air will have a negative impact on the unit and on its ability to properly condition the room.

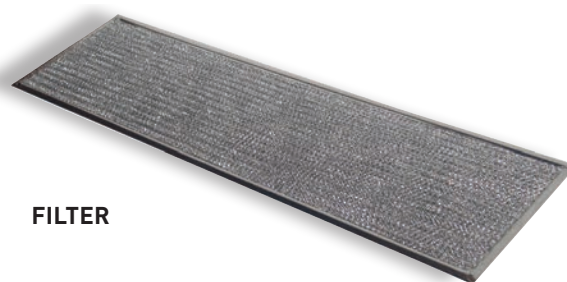

FILTER

FILTER CLEANING:

1. Unit must be in OFF Position.
2. Remove Enclosure (Cabinet) Front Cover – as a safety precaution, disconnect unit from power source by unplugging the line cord.
3. Remove Permanent Air Filter from slides at bottom of Cooling Chassis, by sliding the filter towards you.
4. Wash Air Filter in warm water and biodegradable cleaner.
5. Rinse with clean water and allow to dry completely.
6. Replace Air Filter.
7. (As an alternate cleaning method, the filter may be cleaned on both sides using a vacuum cleaner and a soft brush type attachment).

OPERATING & MAINTENANCE MANUAL – PACKAGED TERMINAL AIR CONDITIONER (PTAC) – RSAN

ROOMSIDE COMPONENT CLEANING – EVAPORATOR COIL AND DRAIN PAN / DRAIN HOSES

IMPORTANT NOTE: In addition to the air filter, the roomside components can be cleaned without removing the PTAC chassis from the wall sleeve. The power cord **MUST** be disconnected from the electrical outlet before carrying out any of the following cleaning!

To access the components within the roomside section of the unit, disconnect the power cord and then remove the unit chassis front cover by unscrewing the hex head retaining screws that hold the front cover in place (use a ¼" hex head driver). You will then have access to the following components:

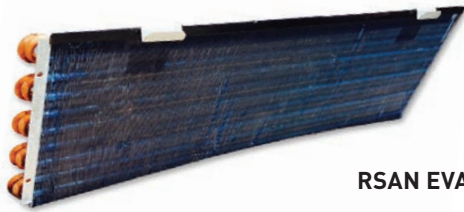

RSAN EVAPORATOR COIL

Evaporator Coil

Check the coil for cleanliness and uniformity of fins. If the coil is dirty, vacuum clean with a soft brush attachment. This is the only form of cleaning that should be carried out within an apartment. If the coil requires additional cleaning, the unit must be removed from the wall sleeve and cleaned using compressed air and/or washed. These operations **MUST** be carried out in a facility properly equipped to handle this type of work in a safe and professional manner.

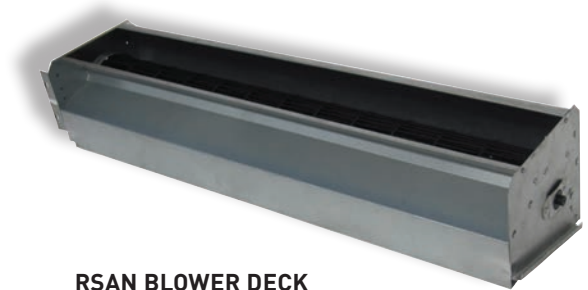

RSAN BLOWER DECK

Evaporator Motor and Blower Assembly

If there is evidence of dirt or dust build-up in the evaporator motor or blowers, they should be cleaned either by vacuum cleaning (if working in an apartment) or by removing the unit to a workshop location and cleaning with compressed air.

Drain Pan / Drain Hose Cleaning

Check the evaporator drain pan and hose assembly for cleanliness by sliding the drain pan assembly towards you, pulling it out approximately 1" – 1-1/2". Check the visible section of the interior of the drain pan for any build-up of dirt or condensate water.

RSAN drain outlets located under the evaporator coil can be checked for any blockages once the chassis front cover is removed.

Always obey safety guidelines for using compressed air in this latter case.

Your ICE AIR PTAC has permanently lubricated motor bearings that do not require additional lubrication. Blowers and motor are factory assembled for quiet performance – if there is any excessive noise and vibration from this assembly, it should be serviced by a qualified technician.



SAFETY WARNINGS:

- MUST BE INSTALLED BY QUALIFIED, TRAINED INSTALLATION PERSONNEL
- MUST BE INSTALLED IN ACCORDANCE WITH ICE AIR INSTALLATION MANUAL AND PROCEDURES
- MUST BE SERVICED BY QUALIFIED, TRAINED PERSONNEL
- ELECTRIC SHOCK HAZARD – DISCONNECT FROM LIVE ELECTRIC CIRCUIT BEFORE SERVICING
- MOVING PARTS HAZARD – DISCONNECT FROM LIVE ELECTRIC CIRCUIT BEFORE SERVICING
- UNIT MUST BE OPERATED WITH ALL CHASSIS SHEET METAL PARTS PROPERLY IN PLACE
- UNIT MUST BE OPERATED WITH ALL ENCLOSURE (CABINET) PARTS IN PLACE
- READ THIS ENTIRE OPERATIONS MANUAL BEFORE OPERATING THE UNIT
- DO NOT OPERATE UNIT WITH FRAYED, BURNT OR DAMAGED LINE CORDS
- UNITS MANUFACTURED AS OF AUGUST 2005 HAVE AN LCDI PROTECTOR BUILT INTO THE PRODUCT LINE CORD

