

Installation Manual

iCoolXC™
ALL CLIMATE COMFORT™

**All Climate
Wall Mounted
Heat Pump**



NOTE: Pictures of components and parts may vary depending on your model.

Contents

General/Safety Information	2
Overview	3
Performance Data	3
Product Diagram	4
Before You Begin	5-7
Installation.....	5
Operation	5
Grounding Instructions.....	6
Warnings	7
Unventilated area.....	7
Qualification of workers.....	7
Instructions for Repairing	
Appliances Containing R32	8-11
Installation	12-13
Tools Required.....	12
Installation.....	12-13
Maintenance	14
Troubleshooting	15
Warranty/Contact Information	16



Thank you for purchasing and installing the Ice Air iCool XC (Cold Climate Wall Mounted Heat Pump). Ice Air is a leading supplier of Heat Pumps, offering superior quality, reliability and efficiency for our customers.

This is a general guide only, and should be treated as such. The information contained in this manual, including but not limited to installation instructions, unit dimensions, and physical/performance data, may vary by project and unit configuration. Ice Air will not be held liable for any information contained in this manual. For questions about installation and unit performance, please contact your local Ice Air representative. Installation and start-up should always be performed by a trained professional.

ATTENTION INSTALLING PROFESSIONAL

Read this manual and familiarize yourself with the specific terms and safety warnings that must be adhered to before attempting to install or service this unit. Precautions listed are intended as supplemental to existing practices. As a professional, you have an obligation to know the product better than the customer. This includes all safety precautions and related items. It is your responsibility to install the product safely and know it well enough to be able to instruct a customer in its safe use as required.

RECOGNIZE THIS SYMBOL AS A SAFETY PRECAUTION.

-  **WARNING:** Ice Air will not be responsible for any injury or property damage arising from improper service or service procedures. If you install or perform service on this unit, you assume responsibility for any personal injury or property damage which may result. Many jurisdictions require a license to install or service heating and air conditioning equipment.
-  **WARNING, HIGH VOLTAGE:** Disconnect all power before servicing or installing unit. Multiple power sources may be present. Failure to do so may cause property damage, personal injury or death.

To ensure that the unit operates safely and efficiently, it must be installed according to these installation instructions and all local codes and ordinances, utilizing the best standards and practices at the time of installation or, in their absence, with the latest edition of the National Electric Code. The proper installation of this unit is described in the following sections. Following the steps in the order presented should ensure proper installation.

Overview

The iCool XC™ is compact and versatile. It's the essence of elegance with up to 25% greater efficiency. All Electric, All Climate Comfort™ with Zero Emissions.

The iCool XC is engineered with advanced heat pump and inverter technology, with requisite R-32 refrigerant for optimal performance under a wide range of construction and climate conditions.

Features

- Industry- leading up to 25% greater efficiency
- Simple Operation
- 4-function Heat, Cool, Dehumidify and Fan modes
- 3 Fan speeds
- Wireless APP control and 24-hour timer.
- Silent Running Option
- Heating performance laboratory tested and certified to 5°F
- Provides cooling operation down to 38°F
- Industry leading up to 25% greater efficiency
- Up to 40 CFM of outside air. No additional wall openings or accessories required.
- Low-noise operation
- Sustainable R32 Refrigerant
- Just two 8-inch round wall openings needed for easy installation,
- Conceals plug and power cord within unit cabinet

Performance Data

SERIES MODEL #	8RSXC09-DH
Cooling Capacity (Btu/h) ¹	7,700
Cooling Capacity Range (Btu/h)	3,000 - 15,000
SEER2 ¹	16.4
Heating Capacity (Btu/h) ²	7,600
Heating Capacity Range (Btu/h)	3,000 - 16,000
HSPF2 ²	8.2
Electric Heater (W)	1,000
Electric Heater (A)	4.8
Voltage	208
Current in Cooling Operation (Amps)	3.4
Power in Cooling Operation (Watts)	703
Current in Heating Operation (Amps)	3.2
Power in Heating Operation (Watts)	670
MCA	14.6
MOCP	15
Airflow (CFM)	310
Outside Air (CFM) ¹ (Optional)	40
Weight (lbs)	84
LOW AMBIENT PERFORMANCE	
Heating Capacity @ 22°F	6,600 + 3,400 Electric Heat
COP @ 22°F	2.44
Heating Capacity @ 13°F	6,100 + 3,400 Electric Heat
COP @ 13°F	2.00
Heating Capacity @ 5°F	5,600 + 3,400 Electric Heat
COP @ 5°F	1.79

Product Diagram

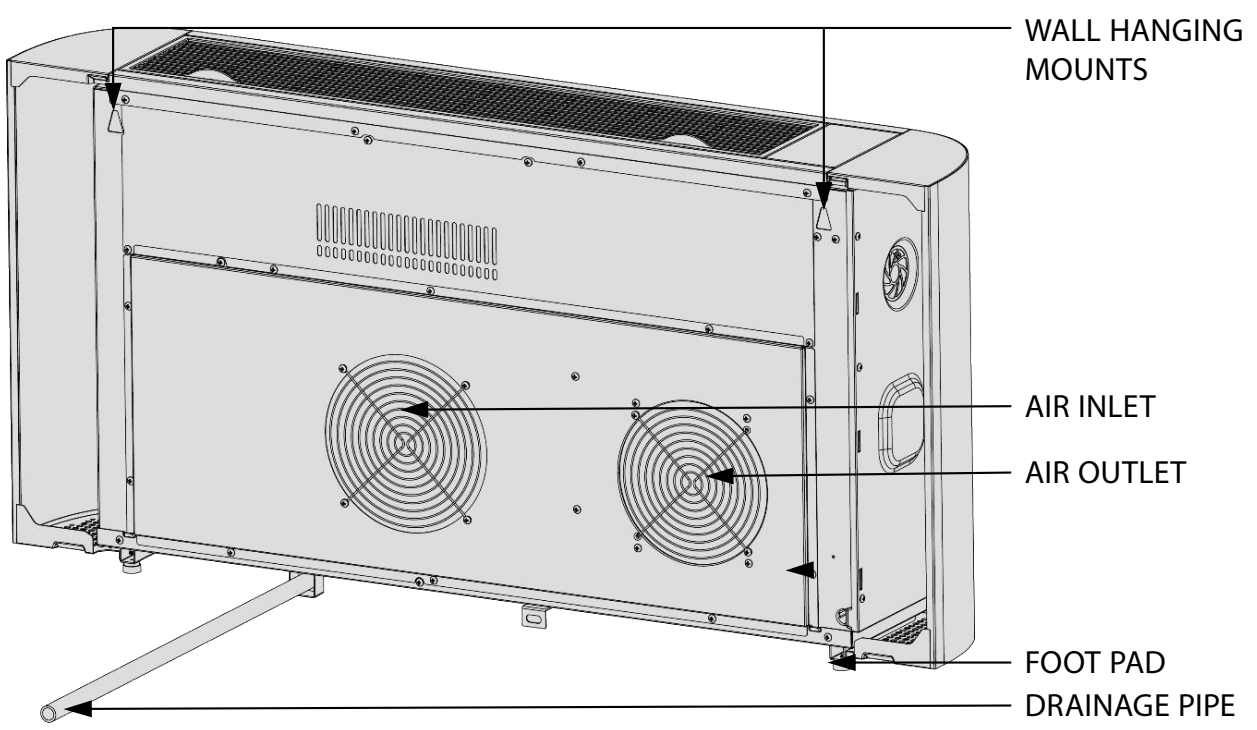
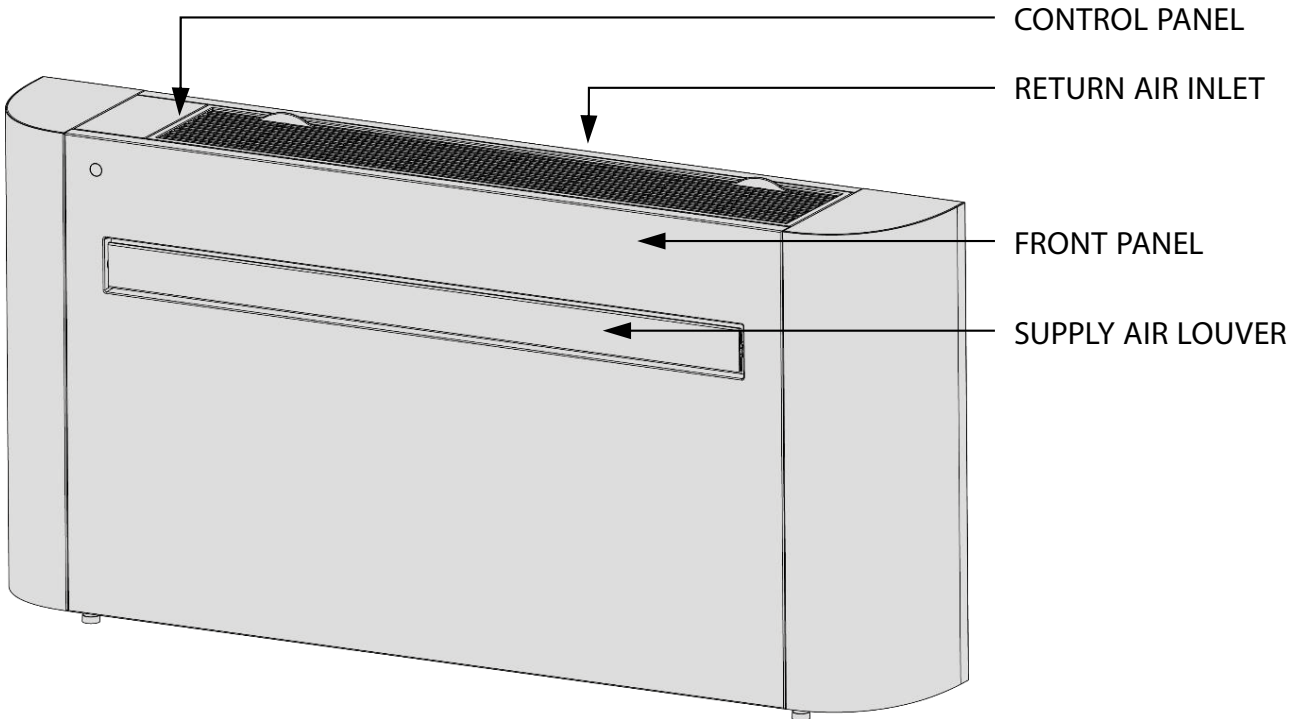

NOTE: Pictures of components and parts may vary depending on your model.

Due to Ice Air's ongoing product development programs, the information in this document is subject to change without notice.

Before You Begin

Installation

To reduce the risk of explosion, fire, death, electric shock, scalding or injury to persons when using this product, follow basic precautions, including the following:

1. Before use, the appliance must be properly installed as described in this manual.
2. Contact the authorized service technician for repair or maintenance of this unit.
3. Contact the installer for installation of this unit.
4. When the power cord is to be replaced, replacement work shall be performed by authorized personnel only using only genuine replacement parts.
5. Installation work must be performed in accordance with the National Electric Code by qualified and authorized personnel only.
6. Connect to a properly rated, protected, and sized power circuit to avoid electrical overload. Always plug into a grounded outlet.
7. Do not under any circumstances, cut or remove the third (ground) prong from the power cord.
8. When installing or moving the appliance, be careful not to pinch, crush, or damage the power cord.
9. Plug in the power plug properly.
10. Do not modify or extend the power cord.
11. Do not start/stop operation by plugging/unplugging the power cord.
12. If the cord/plug is damaged, have it replaced by an authorized service person using authorized replacement parts.
13. Use a dedicated circuit.
14. Do not disassemble or modify the product.
15. Adhere to all industry recommended safety procedures including the use of long-sleeved gloves and safety glasses.
16. Use care when unpacking and installing. The edges of the product may be sharp.
17. Disconnect the power cord or circuit breaker before installing or servicing the appliance.
18. Keep packaging materials out of the reach of children. These materials can pose a suffocation risk to children.
19. Store and install the product where it will not be exposed to temperatures below freezing or exposed to outdoor weather conditions.
20. Do not stored or use gasoline or other flammable vapors and liquids in the vicinity of this or any other appliance.

Operation

1. Use this appliance only for its intended purpose.
2. Never attempt to operate this appliance if it is damaged, malfunctioning, partially disassembled, or has missing or broken parts, including a damaged cord or plug.
3. Repair or immediately replace all power cords that have become frayed or otherwise damaged
4. Do not use a cord that shows cracks or abrasion damage along its length or at either end.
5. Do not run cord under carpets or mats where it could be stepped on and damaged.
6. Keep the cord out from under heavy objects like tables or chairs.
7. Do not place the power cord near a heat source.
8. Do not use an adaptor or plug the product into a shared outlet.
9. Do not tamper with controls.
10. If you detect a strange sound, a chemical or burning smell, or smoke coming from the appliance, unplug it immediately, and contact dealer.
11. Never unplug the appliance by pulling on the power cord. Always grip the plug firmly and pull straight out from the outlet.
12. Do not grasp the power cord or touch the appliance controls with wet hands.
13. The air conditioner is not intended for use by young children or invalids without supervision.

14. Young children should be supervised to ensure that they do not play with the air conditioner. If water enters the product, turn off the power at the main circuit, then unplug the product and call for service.
15. If the product has been submerged, contact the dealer for instructions before resuming use.
16. Unplug the product when unused for long periods.
17. Unplug the product before cleaning. In the event of a gas leak (propane gas, etc.) do not operate this or any other appliance. Open a window or door to ventilate the area immediately.
18. This appliance is not intended for use by persons (including children) with reduced physical, sensory or mental capabilities, or lack of experience and knowledge, unless they have been given supervision or instruction concerning the use of the appliance by a person responsible for their safety.
19. To clean the interior, contact the dealer. Using harsh detergents may cause corrosion or damage to the unit.
20. Do not use solvent-based detergent on the product. Doing so can cause corrosion or damage, product failure, electrical shock, or fire.

Grounding Instructions

1. The power cord of this appliance is equipped with a three-prong (grounding) plug. Use this with a standard three-slot (grounding) wall power outlet to minimize the hazard of electric shock.

The customer should have the receptacle and circuit checked by a qualified electrician to make sure the receptacle is properly grounded. **DO NOT CUT OR REMOVE THE THIRD (GROUND) PRONG FROM THE POWER PLUG.**

Situations when the appliance will be disconnected occasionally; Because of potential safety hazards, we strongly discourage the use of an adapter plug. However, if you wish to use an adapter, a TEMPORARY CONNECTION may be made. Use UL-listed adapter, available from most local hardware stores. The large slot in the adapter must be aligned with the large slot in the receptacle to assure a proper polarity connection.

2. Attaching the adapter ground terminal to the wall receptacle cover screw does not ground the appliance unless the cover screw is metal, and not insulated, and the wall receptacle is grounded to make sure the receptacle is properly grounded.
3. Disconnect the power cord from the adapter, using one hand on each. Otherwise, the adapter ground terminal might break. Do not use the appliance with a broken adapter plug. Situations when the appliance will be disconnected often; Do not use an adapter plug in these situations. Unplugging the power cord frequently can lead to an eventual breakage of the ground terminal. The wall power outlet should be replaced by a three-slot (grounding) outlet instead.

⚠ Warnings

⚠ Do not use means to accelerate the defrosting process or to clean, other than those recommended by the manufacturer. The appliance shall be stored in a room without continuously operating ignition sources (for example: open flames, an operating gas appliance or an operating electric heater)

Do not pierce or burn.

Be aware that refrigerants may not contain an odour.

The instructions should contain the following information:

1. That piping material, pipe routing, and installation shall include protection from physical damage in operation and service, and be in compliance with Federal and Local Regulations.
2. All field joints shall be accessible for inspection prior to being covered or enclosed.
3. The installation of pipe-work shall be kept to a minimum.
4. The provision shall be made for expansion and contraction of long runs of piping;
5. The protection devices, piping, and fittings shall be protected as far as possible against adverse environmental effects, for example, the danger of water collecting and freezing in relief pipes or the accumulation of dirt and debris;
6. The piping in refrigeration systems shall be so designed and installed to minimize the likelihood of hydraulic shock damaging the system;
7. The steel pipes and components shall be protected against corrosion with a rustproof coating before applying any insulation;
8. The flexible pipe elements shall be protected against mechanical damage, excessive stress by torsion, or other forces, and that they should be checked for mechanical damage annually;
9. The precautions shall be taken to avoid excessive vibration or pulsation.

⚠ **When using the product, the room should keep any required ventilation openings clear of obstruction. Notice that servicing shall be performed only as recommended by the manufacturer.**

Unventilated area

1. That an unventilated area where the appliance using flammable refrigerants is installed shall be so constructed that should any refrigerant leak, it will not stagnate so as to create a fire or explosion hazard.
- ⚠ 2. The non-fixed appliance shall be stored in an area where the size corresponds to the room area as specified for operation.
- ⚠ 3. The non-fixed appliance shall be stored in a room without continuously operating open flames or other potential ignition sources.
4. The manufacturer should specify other potential continuously operating sources known to cause ignition of the refrigerant used.
5. The appliance shall be stored so as to prevent mechanical damage from occurring.
6. Non-duct connected appliances containing A2L refrigerants with the supply and return air openings in the conditioned space may have the body of the appliance may be installed in open areas such as false ceilings not being used as return air plenums, as long as the conditioned air does not directly communicate with the air of the false ceiling.

Qualification of workers

1. All operators or refrigeration circuit maintenance personnel should obtain a valid certificate issued by an industry-recognized evaluation agency to determine that they have the qualifications to safely handle refrigerants as required by the industry-recognized evaluation scope.
2. Only perform equipment maintenance and repairs in accordance with the methods recommended by the appliance manufacturer. If other professional is required to assist in maintenance and repairs, they should be carried out under the supervision of personnel qualified to use flammable refrigerants.

Refrigerant (For R32 only)



CAUTION ON FIRE

READ THE MANUAL CAREFULLY BEFORE USING THE APPLIANCE R32 refrigerant gas complies with international environmental directives. This appliance contains approximately 19.40 Oz refrigerant gas.

Instructions for Repairing Appliances Containing R32

1. Checks to the area

Prior to beginning work on systems containing **flammable refrigerants**, safety checks are necessary to ensure that the risk of ignition is minimized. For repair to the **refrigerating system**, the following precaution shall be completed prior to conducting work on the system.

2. Work procedure

Work shall be undertaken under a controlled procedure so as to minimise the risk of a flammable gas or vapour being present while the work is being performed.

3. General work area

All maintenance staff and others working in the local area shall be instructed on the nature of work being carried out. Work in confined spaces shall be avoided.

4. Checking for presence of refrigerant

The area shall be checked with an appropriate refrigerant detector prior to and during work, to ensure the technician is aware of potentially toxic or flammable atmospheres. Ensure that the leak detection equipment being used is suitable for use with all applicable refrigerants, i.e. non-sparking, adequately sealed or intrinsically safe.

5. Presence of fire extinguisher

If any hot work is to be conducted on the refrigerating equipment or any associated parts, appropriate fire extinguishing equipment shall be available to hand. Have a dry powder or CO₂ fire extinguisher adjacent to the charging area.

6. No ignition sources

No person carrying out work in relation to a **refrigerating system** which involves exposing any pipe work shall use any sources of ignition in such a manner that it may lead to the risk of fire or explosion. All possible ignition sources, including cigarette smoking, should be kept sufficiently far away from the site of installation, repairing, removing and disposal, during which refrigerant can possibly be released to the surrounding space. Prior to work taking place, the area around the equipment is to be surveyed to make sure that there are no flammable hazards or ignition risks. "No Smoking" signs shall be displayed.

7. Ventilated area

Ensure that the area is in the open or that it is adequately ventilated before breaking into the system or conducting any hot work. A degree of ventilation shall continue during the period that the work is carried out. The ventilation should safely disperse any released refrigerant and preferably expel it externally into the atmosphere.

8. Checks to the refrigerating equipment

Where electrical components are being changed, they shall be fit for the purpose and to the correct specification. At all times the manufacturer's maintenance and service guidelines shall be followed. If in doubt, consult the manufacturer's technical department for assistance.

The following checks shall be applied to installations using **flammable refrigerants**:

- The actual **refrigerant charge** is in accordance with the room size within the refrigerant containing parts are installed;
- The ventilation machinery and outlets are operating adequately and are not obstructed;
- If an indirect refrigerating circuit is being used, the secondary circuit shall be checked for the presence of refrigerant;
- Marking to the equipment continues to be visible and legible. Markings and signs that are illegible shall be corrected;
- Refrigerating pipe or components are installed in a position where they are unlikely to be exposed to any substance which may corrode refrigerant containing components, unless the components are constructed of materials which are inherently resistant to being corroded or are suitably protected against being so corroded.

9. General work area

Repair and maintenance to electrical components shall include initial safety checks and component inspection procedures. If a fault exists that could compromise safety, then no electrical supply shall be connected to the circuit until it is satisfactorily dealt with. If the fault cannot be corrected immediately but it is necessary to continue operation, an adequate temporary solution shall be used. This shall be reported to the owner of the equipment so all parties are advised.

Initial safety checks shall include:

- That capacitors are discharged: this shall be done in a safe manner to avoid possibility of sparking;
- That no live electrical components and wiring are exposed while charging, recovering or purging the system;
- That there is continuity of earth bonding.

10. Repairs to sealed components

During repairs to sealed components, all electrical supplies shall be disconnected from the equipment being worked upon prior to any removal of sealed covers, etc. If it is absolutely necessary to have an electrical supply to equipment during servicing, then a permanently operating form of leak detection shall be located at the most critical point to warn of a potentially hazardous situation.

Particular attention shall be paid to the following to ensure that by working on electrical components, the casing is not altered in such a way that the level of protection is affected. This shall include damage to cables, excessive number of connections, terminals not made to original specification, damage to seals, incorrect fitting of glands, etc.

Ensure that the apparatus is mounted securely.

Ensure that seals or sealing materials have not degraded to the point that they no longer serve the purpose of preventing the ingress of flammable atmospheres. Replacement parts shall be in accordance with the manufacturer's specifications.

11. Repairs to sealed components

Do not apply any permanent inductive or capacitance loads to the circuit without ensuring that this will not exceed the permissible voltage and current permitted for the equipment in use.

Intrinsically safe components are the only types that can be worked on while live in the presence of a flammable atmosphere. The test apparatus shall be at the correct rating.

Replace components only with parts specified by the manufacturer. Other parts may result in the ignition of refrigerant in the atmosphere from a leak.

12. Cabling

Check that cabling will not be subject to wear, corrosion, excessive pressure, vibration, sharp edges or any other adverse environmental effects. The check shall also take into account the effects of aging or continual vibration from sources such as compressors or fans.

13. Detection of flammable refrigerants

Under no circumstances shall potential sources of ignition be used in the searching for or detection of refrigerant leaks. A halide torch (or any other detector using a naked flame) shall not be used. The following leak detection methods are deemed acceptable for all refrigerant systems. Electronic leak detectors may be used to detect refrigerant leaks but, in the case of **FLAMMABLE REFRIGERANTS**, the sensitivity may not be adequate, or may need re-calibration. (Detection equipment shall be calibrated in a refrigerant-free area.) Ensure that the detector is not a potential source of ignition and is suitable for the refrigerant used. Leak detection equipment shall be set at a percentage of the LFL of the refrigerant and shall be calibrated to the refrigerant employed, and the appropriate percentage of gas (25% maximum) is confirmed.

Leak detection fluids are also suitable for use with most refrigerants but the use of detergents containing chlorine shall be avoided as the chlorine may react with the refrigerant and corrode the copper pipe-work.

- bubble method
- fluorescent method agents

If a leak is suspected, all naked flames shall be removed/extinguished.

If a leakage of refrigerant is found which requires brazing, all of the refrigerant shall be recovered from the system, or isolated (by means of shut off valves) in a part of the system remote from the leak.

Removal of refrigerant shall be according to removal and evacuation.

14. Removal and evacuation

When breaking into the refrigerant circuit to make repairs - or for any other purpose - conventional procedures shall be used. However, for **flammable refrigerants** it is important that best practice is followed since flammability is a consideration. The following procedure shall be adhered to:

- remove refrigerant;
- purge the circuit with inert gas;
- evacuate;
- purge with inert gas;
- open the circuit by cutting or brazing.

The **refrigerant charge** shall be recovered into the correct recovery cylinders.

For appliances containing **flammable refrigerants** the system shall be purged with oxygen-free nitrogen to render the appliance safe for **flammable refrigerants**. This process may need to be repeated several times. Compressed air or oxygen shall not be used for purging refrigerant systems.

For appliances containing flammable refrigerants, refrigerants purging shall be achieved by breaking the vacuum in the system with oxygen-free nitrogen and continuing to fill until the working pressure is achieved, then venting to atmosphere, and finally pulling down to a vacuum.

This process shall be repeated until no refrigerant is within the system. When the final oxygen-free nitrogen charge is used, the system shall be vented down to atmospheric pressure to enable work to take place. This operation is absolutely vital if brazing operations on the pipe-work are to take place.

Ensure that the outlet for the vacuum pump is not close to any **potential ignition sources** and that ventilation is available.

15. Charging procedures

In addition to conventional charging procedures, the following requirements shall be followed.

- Ensure that contamination of different refrigerants does not occur when using charging equipment. Hoses or lines shall be as short as possible to minimize the amount of refrigerant contained in them.
- Cylinders shall be kept in an appropriate position according to the instructions.
- Ensure that the refrigerating system is earthed prior to charging the system with refrigerant.
- Label the system when charging is complete (if not already).
- Extreme care shall be taken not to overfill the refrigerating system.

Prior to recharging the system, it shall be pressure-tested with the appropriate purging gas. The system shall be leak-tested on completion of charging but prior to commissioning. A follow up leak test shall be carried out prior to leaving the site.

16. Decommissioning

Before carrying out this procedure, it is essential that the technician is completely familiar with the equipment and all its detail. It is recommended good practice that all refrigerants are recovered safely. Prior to the task being carried out, an oil and refrigerant sample shall be taken in case analysis is required prior to re-use of recovered refrigerant. It is essential that electrical power is available before the task is commenced.

- a. Become familiar with the equipment and its operation.
- b. Isolate system electrically.
- c. Before attempting the procedure, ensure that:
 - Mechanical handling equipment is available, if required, for handling refrigerant cylinders;
 - All personal protective equipment is available and being used correctly;
 - The recovery process is supervised at all times by a competent person;
 - Recovery equipment and cylinders conform to the appropriate standards.
- d. Pump down refrigerant system, if possible.
- e. If a vacuum is not possible, make a manifold so that refrigerant can be removed from various parts of the system.
- f. Make sure that cylinder is situated on the scales before recovery takes place.
- g. Start the recovery machine and operate in accordance with instructions.
- h. Do not overfill cylinders (no more than 80 % volume liquid charge).

- i. Do not exceed the maximum working pressure of the cylinder, even temporarily.
- j. When the cylinders have been filled correctly and the process completed, make sure that the cylinders and the equipment are removed from site promptly and all isolation valves on the equipment are closed off.
- k. Recovered refrigerant shall not be charged into another **refrigerating system** unless it has been cleaned and checked.

17. Labelling

Equipment shall be labelled stating that it has been de-commissioned and emptied of refrigerant. The label shall be dated and signed. For appliances containing **flammable refrigerants**, ensure that there are labels on the equipment stating the equipment contains **flammable refrigerant**.

18. Recovery

When removing refrigerant from a system, either for servicing or decommissioning, it is recommended good practice that all refrigerants are removed safely.

When transferring refrigerant into cylinders, ensure that only appropriate refrigerant recovery cylinders are employed. Ensure that the correct number of cylinders for holding the total system charge is available. All cylinders to be used are designated for the recovered refrigerant and labelled for that refrigerant (i.e. special cylinders for the recovery of refrigerant). Cylinders shall be complete with pressure-relief valve and associated shut-off valves in good working order. Empty recovery cylinders are evacuated and, if possible, cooled before recovery occurs.

The recovery equipment shall be in good working order with a set of instructions concerning the equipment that is at hand and shall be suitable for the recovery of all appropriate refrigerants including, when applicable, flammable refrigerants. In addition, a set of calibrated weighing scales shall be available and in good working order. Hoses shall be complete with leak-free disconnect couplings and in good condition. Before using the recovery machine, check that it is in satisfactory working order, has been properly maintained and that any associated electrical components are sealed to prevent ignition in the event of a refrigerant release. Consult manufacturer if in doubt.

The recovered refrigerant shall be returned to the refrigerant supplier in the correct recovery cylinder, and the relevant waste transfer note arranged. Do not mix refrigerants in recovery units and especially not in cylinders.

If compressors or compressor oils are to be removed, ensure that they have been evacuated to an acceptable level to make certain that flammable refrigerant does not remain within the lubricant. The evacuation process shall be carried out prior to returning the compressor to the suppliers. Only electric heating to the compressor body shall be employed to accelerate this process. When oil is drained from a system, it shall be carried out safely.

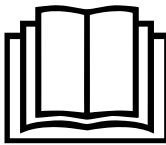
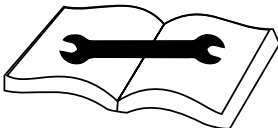
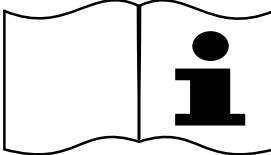
Symbol	Note	Explanation
	WARNING	This symbol shows that this appliance uses a flammable refrigerant. If the refrigerant is leaked and exposed to an external ignition source, there is a risk of fire.
	CAUTION	This symbol shows that the operation manual should be read carefully.
	CAUTION	This symbol shows that a service personnel should be handling this equipment with reference to the installation manual.
	CAUTION	This symbol shows that information is available such as the operating manual or installation manual.

Installation

Package includes:

1. Mounting Bracket & six Mounting Screws
2. Mounting Template
3. Adhesive Sealing Strip
4. Louver (2 per)
5. Louver hardware
6. Fixing plate & Two 4x10 Tapping screws

Tools Required

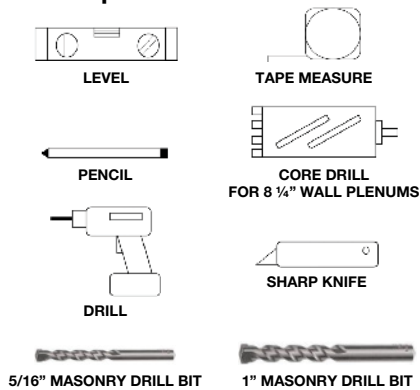

Before starting installation, please ensure you have all suitable equipment available and understand the steps involved in installation. If in any doubt, professional advice should be sought.

Preparing for Installation

Positioning the unit

This unit must be installed on an external wall, as it vents directly out of its rear. Ensure the wall is flat, solid and reliable. Leave at least 4" of space to the left, right and top of the machine. At least 2" of space must be left at the bottom of the unit. Stay away from curtains, plants, faucets, furniture and appliances etc. Figure 1.

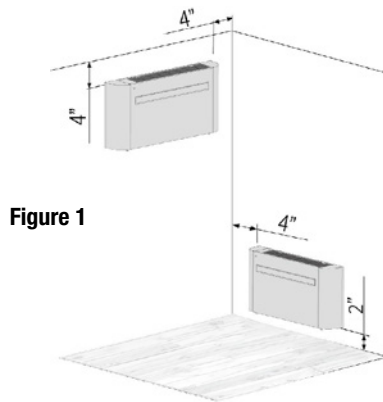

Figure 1

Affix the supplied installation wall template paper in position on the wall, ensuring that the reference line is level using the level tool. Figure 2.

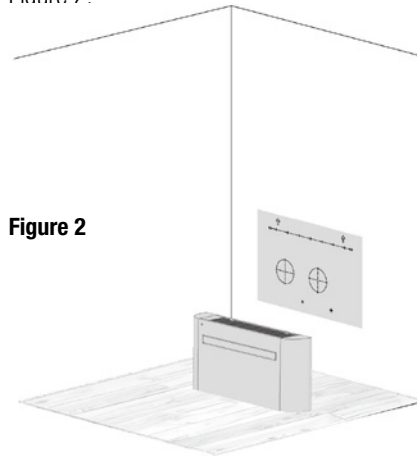

Figure 2

Using the wall template

Drill holes according to the size required in the wall template paper. Two $\varnothing 8 \frac{1}{4}$ " holes and one $\varnothing 1$ " holes must be tilted downward (at least 5 degrees) to prevent water from entering. When drilling holes, ensure the correct position and depth of the holes (two $\varnothing 8 \frac{1}{4}$ " holes and $\varnothing 1$ " holes must be drilled through the wall, and the depth of other holes must exceed $2 \frac{3}{8}$ ").

Note:

1. Please select the appropriate type of drill.
2. Clean the holes to avoid excessive dust and debris.
3. The two $\varnothing 8 \frac{1}{4}$ " holes and $\varnothing 1$ " holes should be drilled through the wall, and the direction is slightly downward, most of

the removed materials may be discharged outward, so please be careful not to touch people or objects. Figure 3.

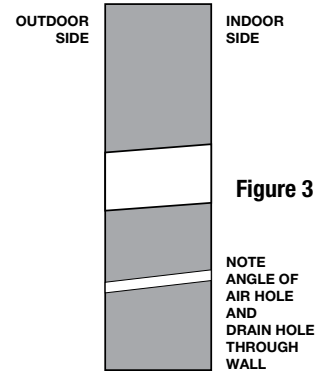

Figure 3

4. The machine performs best when installed on a wall with a thickness not exceeding $9 \frac{1}{2}$ ".

Attaching the Wall Mounting Bracket

1. Please note of the clearances noted on Figure 1.
2. Use the wall template to mark the position of the mounting bracket screw holes. Use the level tool to ensure it is straight and level.
3. Drill the marked holes using a 5/16" drill bit and insert wall plugs. Secure the wall bracket into position using the screws provided. Use anchors if needed to hold 85 lbs. so there is no risk of the unit tipping or falling. Figure 4

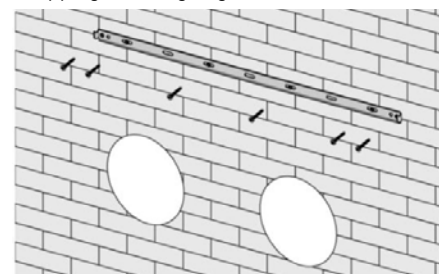

Figure 4

4. Drill 2 holes through wall (angle shown on figure 3) for the in and out air openings. Clean holes before installing the plenum. Apply caulking to the inside flange of the plenum and install the 2 plenums as shown in Figure 5, Seal plenum from the outside if accessible

5. Install the Supply Air Louver as shown on front of unit in Product Diagram on page 4
6. Drill drain hole as shown on the template. Feed the metal pipe from the inside into the wall holes. Figure 5.

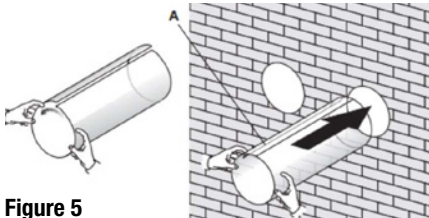

Figure 5

Make sure the tubes sit flush to the interior wall. Insert the indoor fixing ring from the vent cover onto the indoor side of the air vent. Then fold the external vent cover in half. Figure 6

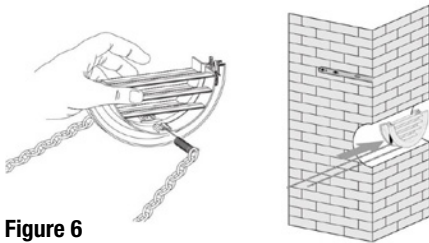

Figure 6

Attach the chains to each side of the vent cover, before sliding the cover outside through the vent hole. Figure 7

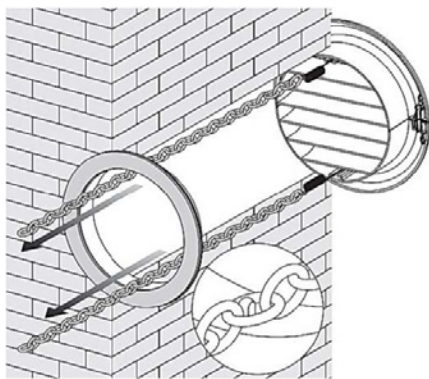

Figure 7

Expand the external cover, before tightly fixing the chains by hooking onto the indoor fixing ring. This will hold the external cover firmly in position. Repeat for the second vent. Once the chains are fitted and secure, any excess chain should be removed by cutting the chain. Figure 8

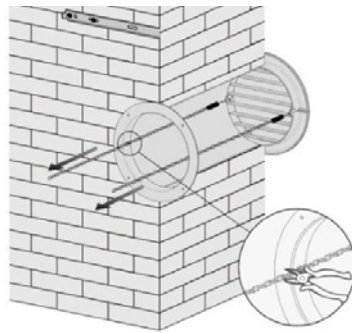

Figure 8

Get the unit ready for mounting on wall.

1. Gradually peel off the backing layer from the Sealing Strip while applying it along the entire perimeter back of the heat pump. Starting on the bottom of the unit in one continuous strip as shown in Figure 9.

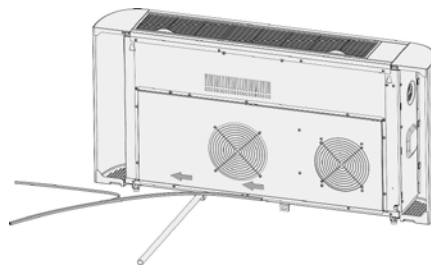

Figure 9

2. Apply the Sealing Strip it to the perimeter of the corners that will be facing the wall
3. After applying, use the knife to cut the sealing strip at the joints between the left and right corner cover plates and the machine body (a total of 4 places) so the end plates can be opened later, as shown in the enlarged callout diagram. Figure 10.

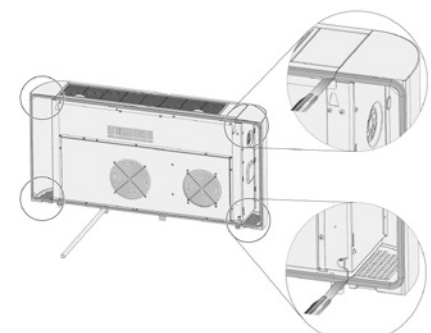

Figure 10

4. Improper application may cause added operating noise

Hanging the unit on the wall.

Lift the unit onto the wall, align the hanging holes with the hooks on the hanging rail and gently rest the unit into place. At the same time, slide the drainpipe through the drainage hole. Figure 11.

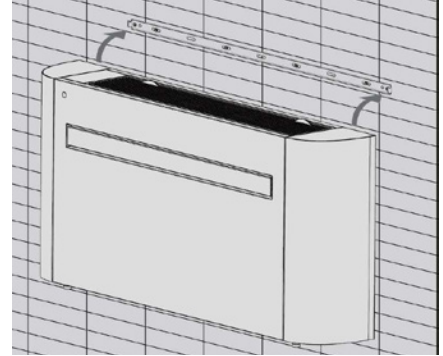

Figure 11

Note:

1. Please ensure that the backside of the unit sits firmly on the wall to avoid additional vibration and noise.
2. The end of the external water pipe must be placed in an open space or drain. Avoid damage or constriction to the drainage pipe to ensure the unit drains.

To attach the fixing plate and gaskets at the bottom of the unit, locate as shown. Use the two 4×10 tapping screws (screws of this specification must be used) to secure the fixing plate to the wall. Figure 12

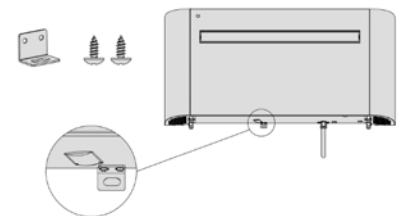

Figure 12

Disassembly and assembly of left and right side panels

1. Dismantling of side panels

- 1.1. Find the fixing screw on the bottom left side panel of the machine and use Phillips screwdriver to remove it.

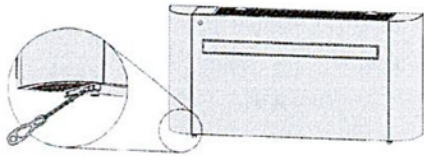

Figure 13

- 1.2. Lift the bottom of the side panel in the direction shown in the diagram.

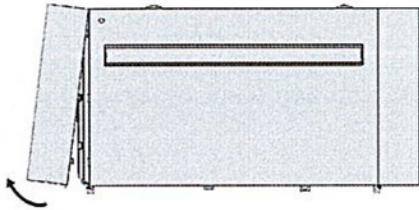

Figure 14

- 1.3. After lifting the side panel to the position shown in above figure, lift the panel at a certain angle in the front and rear directions.
- 1.4. Lift the opening according to steps 1.2 and 1.3 and push the side panel as a whole towards the back of the machine. Slowly remove the side panel parts, and adjust the position appropriately during the process.

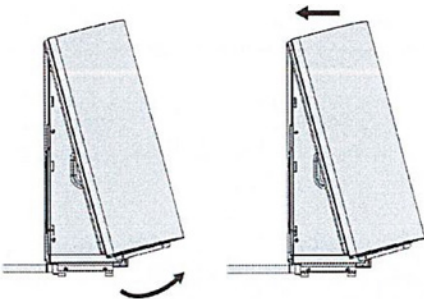

Figure 15

- 1.5. The side panel parts can be removed by following the above steps.

2. Installation of side panels

The installation of the side panel can be completed by following the disassembly steps above in reverse. After the installation of the side panel parts, the position of the sealing strip may be deviated, and it can be adjusted to the appropriate position using a thin rod or a sheet-like object.

Note:

1. The left and right side panels have a symmetrical structure, and the disassembly and assembly are basically the same. Taking the disassembly and assembly of the left side panel as an example.
2. Due to the hook like structure of one part, it needs to be handled carefully and should not be disassembled with brute force.
3. To avoid accidents, non professionals are prohibited from dismantling.

Maintenance

The filter can be removed in the direction shown in the following figure. After removal, the filter can be vacuumed and cleaned. After the surface of the filter is dry, it can be installed in the original place.

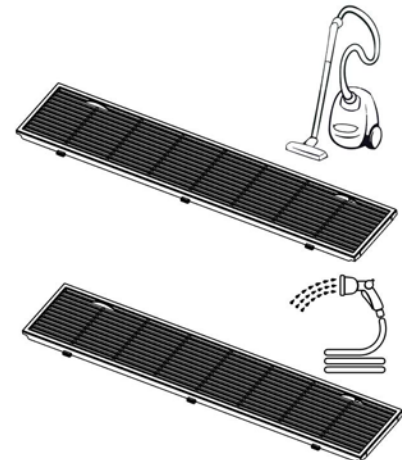
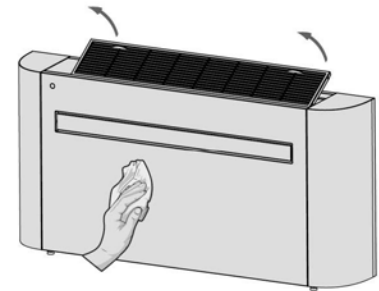

Note:

1. Do not open the chassis to clean the inside of the fuselage, if you really need to clean, please contact professionals;
2. If you want to clean the surface of the fuselage, please use a semi-wet soft cloth or a neutral cleaning agent to scrub, and do not use chemical solvents such as benzene, gasoline, alcohol, etc.
3. Please turn off the unit before cleaning.

Troubleshooting

Do not repair or disassemble the air conditioner. Unqualified repair will invalidate the warranty and may lead to failure, causing injuries and property damage. Only use it as directed in this user manual and only perform operations advised here.

If problems not listed in the table occur or recommended solutions do not work, please contact the service centre.

Problem	Reason	Solutions
The air conditioner does not work	There is no electricity.	Check the unit is plugged in, and the socket is working normally.
	The ambient temperature is too low or too high.	Only use to use the machine with a room temperature between 14°F and 109°F.
	In cooling mode, the room temperature is lower than the desired temperature; in heating mode, the room temperature is higher than the desired temperature.	Adjust the desired room temperature.
	In dehumidification (dry) mode, the ambient temperature is low.	Ensure that the room temperature is above 62°F for dry mode.
	There is direct sunlight.	Check the unit is plugged in, and the socket is working normally.
The cooling or heating effect is poor	Doors or windows are open; there are a lot of people; or in cooling mode, there are other sources of heat (e.g. fridges)	Close doors and windows; increase air conditioning power.
	The filters screen is dirty.	Clean or replace the filter screen.
	The air inlet or outlet is blocked.	Clear obstructions; make sure the unit is installed as per the instructions.
The air conditioner is leaking	The unit is not straight	Use a spirit level to check the unit is horizontal, if not remove from the wall and straighten.
	The drain pipe is blocked	Check the drain pipe to ensure it is not blocked or constricted.
Compressor does not work	Overheat protection operational.	Wait for 3 minutes until the temperature is lowered, and then restart the machine.
The remote control does not work.	The remote control is not aligned with the direction of the remote-control receiver.	Let the remote control get close to the air conditioner, and make sure that the remote control directly faces to the direction of the remote-control receiver.
	Batteries poor.	Replace batteries.

Error Codes

Fault Code	Fault Description
F1	Compressor IPM error
F2	PFC/IPM error
F3	Compressor start error
F4	Compressor running out of step
F5	Location detection loop failure
F6	PCB and driver board communication error
F7	Coil sensor error(outdoor)
F8	Sensor on suction pipe error
FA	Phase current overcurrent protection
FE	EE error (outdoor)
FL	Water-full protection
P1	Over-heat protection on top of compressor
P2	DC bus voltage Undervoltage protection
P3	AC Input voltage protection
P4	AC over-current protection
P5	AC undervoltage protection
P6	Coil tube overload protection(indoor)
P7	Defrost protection on coil tube(indoor)
P8	Zero-crossing fault detection(indoor)
PA	Return air sensor temperature abnormal protection
PC	Coil tube overload protection(outdoor)
PE	Abnormal refrigerant circulation
PH	Exhaust temperature protection
E0	Sensor on suction pipe error
E1	Temperature sensor error(indoor)
E2	Sensor error on indoor coil tube
E3	DC fan Feedback failure(indoor)
E4	Communication error
E5	Water-splash motor error
E6	Temperature sensor error (outdoor)
E7	Fan motor error (outdoor)
E8	Fan feedback fault
EE	EE error (indoor)
EA	Reversing fault of four-way valve
EB	Fluoride deficiency protection

Limited Warranty

Twelve (12) Month Warranty of entire Packaged Terminal Equipment

Ice Air, LLC ("Ice Air" or the "Company") warrants, solely to the person or entity that directly purchased the packaged terminal system from the Company (the "Original Owner"), that the entire packaged terminal system is free from defects in material and workmanship for a period of twelve (12) months from the date of delivery (the "Twelve Month Warranty"). Any part or portion thereof which becomes defective under normal use during the period of this warranty will be repaired or replaced, provided Ice Air's examination shall prove to its satisfaction that the part was or became defective under normal use. Ice Air's obligations under this warranty are subject to the satisfaction of the conditions set forth in the last paragraph of this Section and are limited to: (a) repairing the defective part or (b) furnishing a replacement part provided the defective part is returned to Ice Air, without shipping damage, transporting charges prepaid. No reimbursement will be made for expenses incurred in making field adjustments or replacements unless specifically authorized in writing by the Company.

Except as otherwise provided in the last sentence of this paragraph, the Company is not obligated under this warranty for field labor such as service for inspection, removing, packing and/or reinstalling water source unit, nor for the return transportation charges. In addition, the Company is not obligated under this warranty to make reimbursement of the labor or service charges of any other party. Notwithstanding the foregoing, labor provided by or at the direction of the Company during the twelve (12) month period from the date of delivery referred to in the initial paragraph above, in connection with the Twelve Month Warranty of parts provided in the initial paragraph above, is included in such warranty, solely in the case in which a packaged terminal system is sold by the Company to an Original Owner for use in a new facility to be constructed and located in the greater New York City metropolitan area. For the avoidance of doubt, except in the case described in the preceding sentence, the Company has no obligation under this warranty to provide for field labor or to make reimbursement of the labor or services charges of any other party, provided, however, that the Company, in its sole and absolute discretion, may elect to do so, so long as (i) such election is set forth in a writing signed by the Company and (ii) the facility at which the applicable packaged terminal system is or will be installed is located in the greater New York City metropolitan area (the "Metropolitan Area").

The obligations of the Company set forth in the preceding paragraphs of this Section are in all cases subject to the satisfaction of the following conditions: (x) the Company shall have received proof, satisfactory to the Company, of the purchase by the Original Owner from the Company of the packaged terminal system that is the subject of the Original Owner's claim, (y) all amounts due and payable to the Company on or prior to the date of such claim in respect of such packaged terminal system shall have been paid in full and (z) nothing shall exist or occur that relieves the Company, in accordance with the terms of this agreement, from the performance of its warranty obligations hereunder.

OPTIONAL Extended Refrigeration Circuit Warranty

2nd – 5th year compressor parts only; labor not included

The Optional Extended Refrigeration Circuit Warranty MUST be purchased from Ice Air within thirty (30) days from date of delivery to be valid. The hermetically sealed refrigeration circuit (consisting of the motor, compressor assembly, evaporator coil, coaxial / condenser coil, and interconnecting tubing) is warranted to the Original Owner for four additional years from date of the expiration of the twelve-month Warranty. Components under this warranty will be supplied at Ice Air's expense provided the failed component is returned to Ice Air. This optional warranty does not include any other parts of the equipment such as fans, fan motors, controls, cabinet parts, electrical relays, capacitors, protective devices, or wiring. Ice Air is not obligated under this warranty for field labor such as service for inspection, removing, packing, and/or reinstalling the refrigeration circuit, nor for return transportation charges. In addition, the Company is not obligated under this warranty to make reimbursement of the labor or service charges of any other party. Ice Air reserves the right to make a handling and inspection charge in the case of parts or equipment improperly returned as defective and/or as being in warranty.

To obtain assistance under the parts warranty or to purchase the optional extended warranty, simply contact Ice Air Customer Service at 80 Hartford Avenue, Mount Vernon, New York 10553 Phone 914-668-4700.

Additional warranty options include:

2nd – 5th year full unit parts only warranty

2nd – 5th year compressor parts and labor warranty, so long as such labor is performed in the NY Metropolitan Area

2nd – 5th year complete parts and labor warranty (Full unit coverage), so long as such labor is performed in the NY Metropolitan Area.

All Warranties (which must be purchased separately) constitute the Original Owner's sole remedy. They are given in lieu of all other warranties. Ice Air is not liable for incidental or consequential damages, whether the theory is breach of this or any warranty, negligence, or strict tort. No person (including any agent, salesman, dealer, or distributor) has authority to expand Ice Air's obligation beyond the terms of these express warranties, or to state that the performance of the product is other than that published by Ice Air. In addition, neither the Original Owner nor any such person has the right to sell, transfer or assign, or attempt to sell, transfer or assign, any rights of the Original Owner in or to the warranties provided for herein, no such sale, transfer or assignment shall be binding upon Ice Air and any such sale, transfer or assignment is null and void and of no force or effect.

General Conditions

The above warranties are void if Ice Air's equipment has been damaged, misused, subjected to abnormal use or service or its serial number has been altered, defaced, or removed, or payment for the equipment is in default. Ice Air is not responsible for service to correct conditions due to misapplication, faulty or improper installation, inadequate wiring, incorrect voltage conditions or unauthorized opening of the refrigeration circuit, nor for consequential damages. In case Ice Air's equipment is installed in conjunction with cabinets, grills, louvers, controls, or other parts manufactured by others, these warranties shall apply only to Ice Air's manufactured portion of the equipment. The conditions of the standard warranty plan are effective for 12 months from the date of equipment delivery. Ice Air reserves the right to make a handling and inspection charge in the case of parts or equipment improperly returned as defective and/or as being warranty.

Important Disclaimers

Ice Air Has No Responsibility For:

(A) Certain Damages

The following are the responsibility of the user. None of the following constitutes a manufacturing defect, and each is expressly excluded from the warranty plan:

- 1) Failure of unit to operate satisfactorily due to improper amount of air on evaporator coil or air supply to air cooled condensers.
- 2) Damage to unit or unsatisfactory operation due to improper cleaning of evaporator coil or use of unit in corrosive atmosphere locations such as chemical plants, refineries, or salt spray areas.
- 3) Damage to unit from unsatisfactory operation due to blown fuses, inadequate or interrupted electrical service, use of improper electrical protective devices or operation of unit on power supply other than covered by nameplate rating of unit.
- 4) Damage due to failure to properly maintain unit.
- 5) Damage due to transportation or handling prior to and during installation.
- 6) Damage due to accident or from alteration, improper installation or tampering.
- 7) Failure to clean or replace filter timely.
- 8) Misapplication of equipment.
- 9) Damage due to deviation from original design and intended use of equipment.
- 10) Damage due to use of additional accessories either unapproved or approved but modified or manipulated.

(B) Installation

Ice Air is not responsible for the design, execution, and performance of the installation method or any of the accessory items used during installation such as seals, caulking, weatherproofing, supporting structures, attachment means, louvers and frames supplied by others.

(C) Check, Test and Start

Check, Test and Start of the air conditioners by an experienced person is the responsibility of the installing contractor. This consists of physically confronting each conditioner operating in both heating and cooling modes and correcting any minor deficiencies noted. After the equipment leaves the factory, it may become damaged or maladjusted during transportation or on the job. Sometimes wires are disconnected accidentally, or fan motors move on their bases due to rough handling, causing fans to strike; a component(s) may be inoperable. The correction of such conditions is part of the Check, Test and Start. Note that unless otherwise specifically agreed to in writing, Ice Air has no obligation to perform, nor does the price of its equipment include field labor in connection with the performance of, these Check, Test, and Start procedures (or the like).



80 Hartford Avenue, Mount Vernon, NY 10553
Tel: 877-ICE-AIR-1 (877-423-2471)
Fax: 914-668-5643
email: service@ice-air.com

ice-air.com

© 2025 by Ice Air, LLC

ICE6164 10/25