

**Operating and
Maintenance Manual**

CHPW

**Slope or Flat Top
Console Unit**

Water Source Heat Pump
(WSHP) Unit

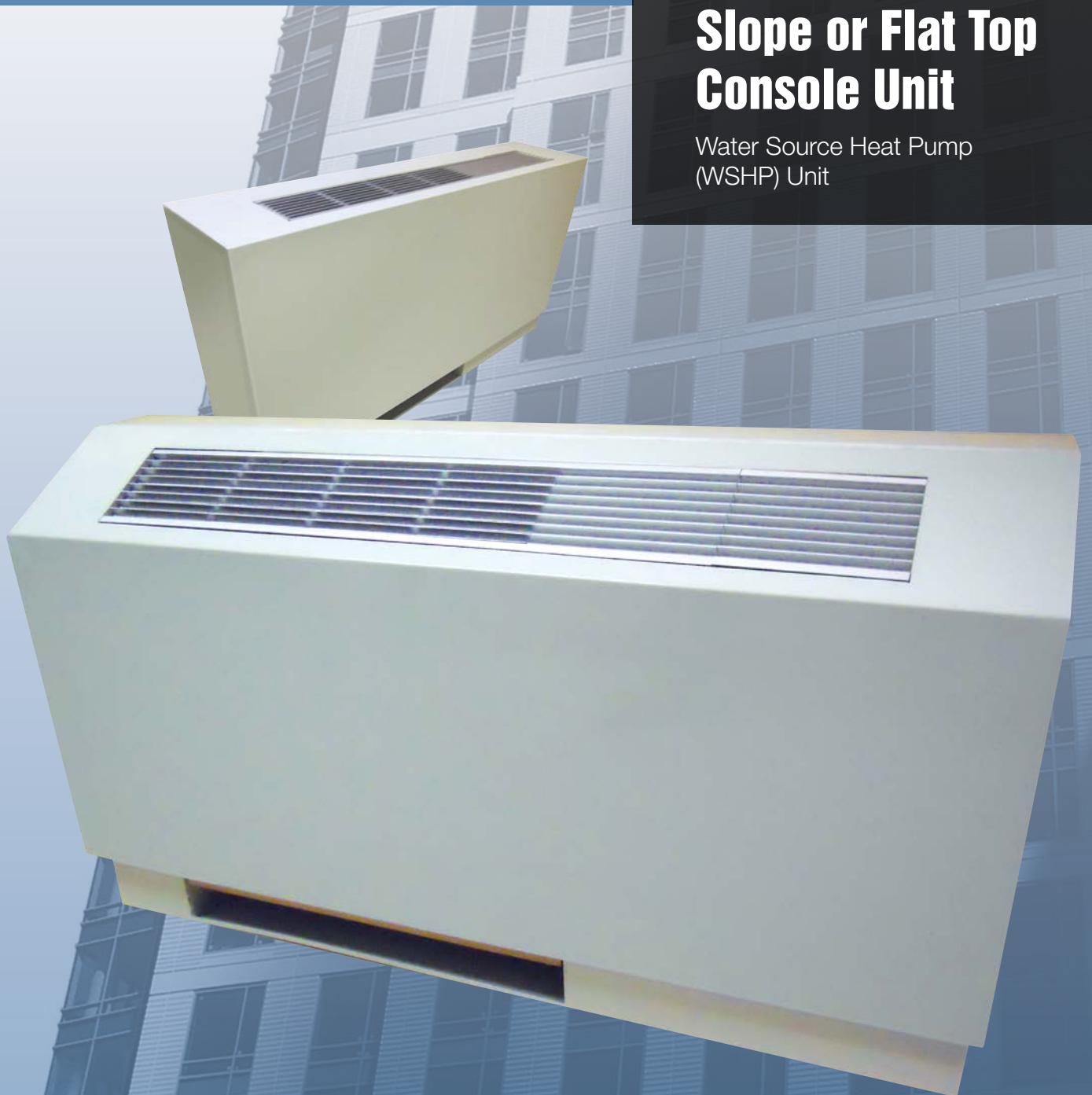



Contents

Welcome..... 2
Consumer Safety Information/Guidelines ... 3
Components and Parts View 4
Nomenclature 5
Controls 6
 LCD Programmable Operation.....7-9
Maintenance 10-11
Troubleshooting 12
Warranty/Contact Information 16

Welcome

Congratulations on your selection of the ICE AIR Water Source Heat Pump (WSHP). The WSHP is a combination cooling and heating unit that provides an efficient room by room source for comfort conditioning of your living environment.

ICE AIR WSHP Console units are built to a high standard of quality and reliability, employing commercial grade components and heavy duty, galvanized sheet metal casings. With proper maintenance and usage, ICE AIR WSHPs should provide many years of efficient, quiet and trouble-free comfort.

To enhance the use of your ICE AIR equipment, you will want to read and carefully follow all of the instructions contained in this Operating and Maintenance Manual. We recommend that you pay special attention to the Safety and Warning Information section at the beginning of this Manual, and to the various safety advisories throughout this Manual.

Please retain this Manual for your future reference. We suggest that you keep it with other important documents and product manuals. If your unit has optional features, they will be explained in a separate instruction sheet specific to that option.

On behalf of ICE AIR, and our network of distributors and dealers, we are happy to welcome you to our base of satisfied customers!

We recommend that you record the following information about your ICE AIR product(s).

Location	Model No.	Serial No.
Living Room		
Master Bedroom		
Bedroom		
Dining Room		
Other		

Precautions and preparations listed are for general knowledge and to define basic guidelines. Local codes and existing practices should be observed and performed by a professional.

Due to ICE AIRs ongoing product development programs, the information in this document is subject to change without notice.

Consumer Reference Information

For safe and optimal enjoyment of your ICE AIR unit, please read the following consumer safety and operating notes carefully before operating your equipment!

⚠️ RECOGNIZE THIS SYMBOL AS A SAFETY PRECAUTION.

- ⚠️ **WARNING:** ICE AIR will not be responsible for any injury or property damage arising from improper service, or service procedures. If you install or perform service on this unit, you assume responsibility for any personal injury or property damage which may result. Many jurisdictions require a license to install or service heating and air conditioning equipment.
- ⚠️ **WARNING HIGH VOLTAGE:** Disconnect all power before servicing or installing unit. Multiple power sources may be present. Failure to do so may cause property damage, personal injury or death.

Safety Guidelines

Read this entire manual before operating the unit.

- ⚠️ **WARNING:** This unit MUST be serviced only by professionally trained and qualified technicians. Do NOT attempt to maintain or service this unit on your own – severe injury and death can occur from electric shock, moving parts, and other hazards.
- Your ICE AIR unit must be properly installed and commissioned to operate correctly. Improper unit installation, adjustment or commissioning, and/or improper heating system installation and connection can lead to equipment malfunction and hazardous operating conditions, and may void your warranty. If you have any doubt about the proper installation of your ICE AIR unit, please contact your property manager at once to have a qualified technician inspect the equipment.
- Your ICE AIR units must each be wired on an individual, dedicated electrical circuit with the correct voltage and proper amperage (capacity) to match the unit nameplate requirements.
- Each unit's electrical circuit must have a proper overcurrent protection device, employing an approved circuit breaker or fuse of the proper rating under NEMA and local building codes.

⚠️ **WARNING:** Every unit contains refrigerant within a sealed and pressurized refrigerant system. This system must not be opened or tampered with and any refrigeration system repairs MUST be carried out by trained technicians. Refrigerant must be properly handled and recycled per EPA regulations and guidelines.

⚠️ **WARNING:** Do NOT operate the unit with frayed, burnt or damaged electrical wires!

⚠️ **WARNING:** Do NOT operate the equipment when in doubt – have it inspected first!

IMPORTANT: It is not the intent of this maintenance manual to correct any installation deficiencies. If you have any doubt about the proper initial installation (or re-installation after servicing) of your ICE AIR unit(s) – noisy or inefficient unit operation, frayed or damaged electrical connections, improper unit appearance, etc. – please contact a trained servicer or building maintenance staff immediately.

The following physical conditions must be maintained for proper unit operation:

Air flow must be unobstructed into and out of the unit return air opening.

- Have the unit filter properly cleaned and serviced to prevent air blockage from dirt and dust within the filter media.

Intended for indoor use only.

Proper installation and operating environment must be maintained. Therefore:

- Do not operate the unit in corrosive environments such as chemical plants, refineries or salt spray areas.
- Operate only with proper electrical service and protective circuit breakers or fuses in place.
- Operate only with all unit and enclosure sheet metal parts in place and properly installed.
- In areas of high concentrations of dirt, dust, pet dander or pollutants, clean the filter often (at least monthly).
- Do not clean the unit with any solvents or cleaning solutions that may damage the equipment.
- Understand and follow the unit operating instructions before using your ICE AIR equipment.

Components and Parts View

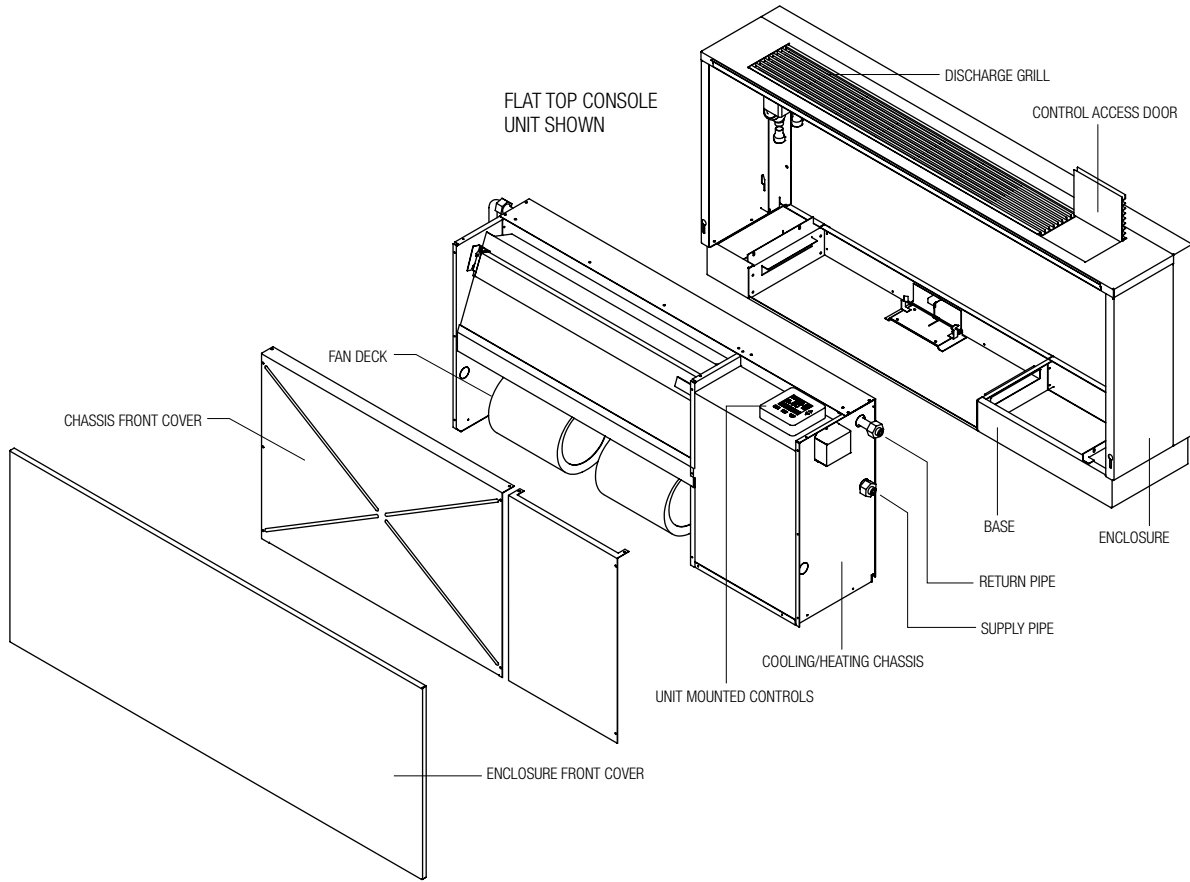



Nomenclature

Model Selection	8	CHPW	09	-	1	P	D	P	S	X	X	-	A	A	X	A	X	X	X	X	
Item Number	1	2	3	-	4	5	6	7	8	9	10	-	11	12	13	14	15	16	17	18	19
	Primary Part				Secondary Parts							Valve Package Parts									

Item 1	8	Voltage	8 - 208V-1PH-60Hz	7 - 277V-1PH-60Hz	6 - 220V-1PH-50Hz	
Item 2	CHPW	Unit	CHPW - Console			
Item 3	09	Capacity (Btuh)	09 - 9000	13 - 13000	16 - 16000	19 - 19000
Item 4	1	Configuration	9 - Flat Top Standard Universal Piping 10 - Flat Top RH Piping 11 - Flat Top LH Piping 12 - Flat Top Chassis TBD Piping 13 - Flat Top Subbase and Chassis Univ. Piping 14 - Flat Top Subbase and Chassis RH Piping 15 - Flat Top Subbase and Chassis LH Piping 16 - Flat Top Subbase and Chassis TBD Piping 17 - Flat Top Chassis Only Universal Piping 18 - Flat Top Chassis Only RH Piping 19 - Flat Top Chassis Only LH Piping 20 - Flat Top Chassis Only TBD Piping		21 - Slope Top Standard Universal Piping 22 - Slope Top RH Piping 23 - Slope Top LH Piping 24 - Slope Top Chassis TBD Piping 25 - Slope Top Subbase and Chassis Univ. Piping 26 - Slope Top Subbase and Chassis RH Piping 27 - Slope Top Subbase and Chassis LH Piping 28 - Slope Top Subbase and Chassis TBD Piping 29 - Slope Top Chassis Only Universal Piping 30 - Slope Top Chassis Only RH Piping 31 - Slope Top Chassis Only LH Piping 32 - Slope Top Chassis Only TBD Piping	
Item 5	P	Motor	P - PSC E - ECM B - BLDC			
Item 6	D	Power Source	D - Disconnect Switch (Non Fused) X - Chassis Only			
Item 7	P	P-Trap	P - Internal			
Item 8	S	Drain pan	P - Powder Coated Galvanized S - Stainless Steel			
Item 9	X	Riser Set	X - Not Applicable			
Item 10	X	Casing Stand	X - Not Applicable			
Item 11	A	Flow Control	A - Autoflow Valve	B - Manual Balancing Valve	C - Manual Circuit Setter X - None	
Item 12	A	Autoflow Valve (GPM)	A - 1.50	B - 2.25		
Item 13	X	Controls	1 - Unit Mounted AcuZone ELA-8842 Thermostat (R14) 2 - Wired for 24V Thermostat (others) (RO2) 3 - Wired for AcuZone ELA-8842 Thermostat (RO3)		4 - Wired for Wireless WiFi Thermostat 5 - Wired for Wireless Thermostat 6 - Wired for WiFi Thermostat	
Item 14	A	Valve Options	A - Motorized Valve - Normally Open (Supply) B - Motorized Valve - Normally Closed (Supply) C - Motorized Valve - Normally Open (Supply) - Strainer (Supply) D - Motorized Valve - Normally Closed (Supply) - Strainer (Supply)			
Item 15	X	Condensate Pump	I - Internal	E - External	X - None	
Item 16	X	Air Vents	E - Bleed Elbow	T - Bleed Tee	X - None	
Item 17	X	Removable Chassis	C - Yes X - No			
Item 18	S	Enclosures	X - Not Applicable			
Item 19	X	Compressor Blanket	B - Yes X - None			

Precautions and preparations listed are for general knowledge and to define basic guidelines. Local codes and existing practices should be observed and performed by a professional.
 Due to ICE AIRs ongoing product development programs, the information in this document is subject to change without notice.

Controls

All standard ICE AIR units are equipped with microprocessor control board ELA-9830 with the following thermostat options.



If your unit has 3rd party wall mounted or remote controls, see the separate operating instructions supplied with those controls.

7-Day Programmable (Optional)



- 5/2 or 7-day programs for highest efficiency
- Factory or field-set temperature limits
- Large clear display – in any lighting condition
- Auto changeover mode
- Easy to program

Wireless Thermostat (Optional)



- Easy programming
- Settings for morning, day, evening and night
- Clear backlit display readable in any lighting condition
- Auto changeover mode
- Optional remote temperature sensor

Nest “Learning Thermostat” (Optional)



- Programmable to save energy
- Remembers temperatures and time/day to create customized schedule
- Easy to install and program – self-learning technology
- Sleek, ultra-modern, efficient design
- Integrates with mobile devices/smart phones (Nest Mobile app)
- Clear backlit display readable in any lighting condition
- Auto changeover mode
- Optional remote temperature sensor

LCD Programmable Operation



Feature List

- Operates on 2-stage Heat and 2-stage Cool
- 7 programs (Mo, Tu, We, Th, Fr, Sa, Su) or 5-2 programs (Mo-Fr, Sa-Su)
- 4 Separate Time and Temperature Settings for each mode
- Heat and Cool set points for each program
- EPROM stores Heat and Cool program settings
- Temporary Program Override
- Permanent Program Override
- Compressor Short Cycle Protection
- LCD Backlighting
- Low Temperature Protection
- Lockout Safety feature

Operating Specifications

- Temperature Measurement: 0°C ~ 40°C/32°F ~ 99°F
- Accuracy: ±0.5°C/1°F
- Voltage: 18-30VAC
- Temperature Controllable Range: 5°C~35°C/55°F ~ 95°F
- Resolution: 0.5°C/1°F
- Operating Temperature: 0 – 50°C/32 – 122°F
- Storage Temperature: 5 – 50°C/41 – 122°F

User Interface

Button	Press	Hold
▲	UP/Override mode	UP/Permanent Override mode
▼	DOWN/Override mode	DOWN/Permanent Override mode
ON/OFF	ON/OFF	-----
MODE	Set operation mode	Internal Setting
FAN	Set fan speed/Confirm	-----

The temperature reading that is on constant display is the ambient room temperature.

The Cool limit setting is 55°F to 95°F.

The Heat limit setting is 51°F to 91°F.

Operation

Normal Mode:

1. Press ON/OFF to turn on thermostat.
2. Press MODE to change the system mode.
3. There are three operation modes:
Cool mode, Heat mode, Auto mode.

Cool Mode

1. To activate Cool mode, press the MODE button until COOL displays.
2. Press UP/DOWN arrow buttons to your desired temperature.
3. Compressor will cycle when temperature reaches the set point. After compressor stops, allow at least 3 minutes before restarting (this applies only if you have manually turned the unit off or reset the thermostat – during normal running conditions, the unit will automatically allow for the required restart delay).

Heat Mode

1. To activate Heat mode, press the MODE button until HEAT displays.
2. Press UP/DOWN arrow buttons to your desired temperature.
3. The unit will cycle until the set temperature is achieved and then will continuously cycle to maintain the set temperature.



Auto Mode

1. To activate Auto mode, press the MODE button until AUTO displays.
2. Press UP/DOWN arrow buttons to set desired Heat temperature.
3. Wait 5 seconds for COOL to appear.
4. Press UP/DOWN arrow buttons to set desired Cool temperature.
5. The unit will automatically cycle between Heat and Cool modes if unit exceeds desired set points. The temperature reading that is on constant display is the ambient room temperature.

Set Day and Time

Enter internal setting mode by pressing and holding MODE button for 5 seconds.

Time Setting

Set Clock/Day is flashing

1. Press MODE button to select Edit Clock/Day.
2. Use UP/DOWN buttons to adjust hours (12 hr).
3. Press MODE to select minutes.
4. Use UP/DOWN buttons to adjust minutes.
5. Press MODE to select days.
6. Use UP/DOWN buttons to adjust days. Press FAN when complete.

Programming Your Thermostat

Enter internal setting mode by pressing and holding MODE button for 5 seconds.

Press ON/OFF to select Schedule (Schedule is flashing)

1. Press MODE button to select EDIT SET SCHEDULE.
2. Use UP/DOWN to select DAY.
3. Press MODE to edit.
4. Use UP/DOWN to select Time (adjustable in 10 minute increments).
5. Press MODE to edit Heat setting.
6. Use UP/DOWN to select temperature.
7. Press MODE to edit Cool setting.
8. Use UP/DOWN to select temperature.
9. Press MODE to set next time frame.
10. Follow the screen, and repeat steps 2 through 9 to adjust 7-day schedule programming.
11. Press FAN when complete.
12. If no button is pressed for 15 seconds, it will return to normal mode automatically.

Below is the default program.

The default selection is 5-2 day program.

Days	Event	Time	Heat	Cool
MON-FRI	WAKE	6:00 AM	70° F (21° C)	78° F (26° C)
	LEAVE	8:00 AM	62° F (17° C)	85° F (29.5° C)
	RETURN	6:00 PM	70° F (21° C)	78° F (26° C)
	SLEEP	10:00 PM	62° F (17° C)	82° F (28° C)
SAT-SUN	WAKE	6:00 AM	70° F (21° C)	78° F (26° C)
	LEAVE	8:00 AM	62° F (17° C)	85° F (29.5° C)
	RETURN	6:00 PM	70° F (21° C)	78° F (26° C)
	SLEEP	10:00 PM	62° F (17° C)	82° F (28° C)

Changing Program Schedule and Temperature Limits

Enter internal setting mode by pressing and holding MODE button for 5 seconds.

Press ON/OFF twice to select Settings (Settings is flashing)

1. Press MODE button to select Edit "Settings."
2. Use UP/DOWN to select 7 Day or 5-2 Day.
3. Press MODE to edit Heat temperature limit.
4. Use UP/DOWN to set temperature. Default internal setting: Heat limit 90°F
5. Press MODE to edit Cool temperature limit.
6. Use UP/DOWN to set temperature. Default internal setting: Cool limit 60°F
7. Press FAN when complete. The Cool limit setting should be at least 4°F higher than the Heat limit setting.
8. If no button is pressed for 15 seconds, it will return to normal mode automatically.

Temporary Program Override

1. When thermostat is ON, the program set point can be temporarily overrode by pressing UP or DOWN. OVERRIDE icon will turn on. Press UP or DOWN to select the set point.
2. In Heat mode, Heat set point can be adjusted.
3. In Cool mode, Cool set point can be adjusted.
4. In Auto mode, Heat set point will be set first and press UP or DOWN to set the Heat set point. Press FAN to confirm the Heat set point. Cool set point will be set second and press UP or DOWN to set the Cool set point. Press FAN to confirm the Cool set point.
5. Temporary Override will be canceled if user changes the operation mode or the unit enters the next program time session.

Permanent Override

1. Hold UP and DOWN button for 2 seconds to enter Permanent Override mode. Permanent Override icon will turn on.
2. In Heat mode, Heat set point can be adjusted.
3. In Cool mode, Cool set point can be adjusted.
4. In Auto mode, Heat set point will be set first and press UP or DOWN to set the Heat set point. Press FAN to confirm the Heat set point. Cool set point will be set second and press UP or DOWN to set the Cool set point.
5. Permanent Override will be canceled if user changes the operation mode or turns off the unit.
6. Hold FAN button 5 seconds to cancel the Permanent Override mode.

Sequence of Operation for Water Source Heat Pump

Cooling Cycle

- Set the thermostat for Cooling.
- If applicable, the motorized valve opens as long as the thermostat calls for Cooling.
- This sends a 24-volt signal to the terminal to the compressor contactor and the compressor starts.
- At the same time a 24-volt signal flows through the fan relay and the blower starts in HIGH speed, if the unit is in Auto Fan Mode. If the unit is in manual mode, set by the user, then the fan continuously blows in the user set speed.
- If in Auto Fan Mode, once the thermostat is within 2 degrees of set point, the fan drops to LOW speed.
- Once the thermostat is satisfied, it sends a 24-volt signal to the compressor contactor and compressor turns OFF.
- If in Auto Fan Mode, this ends the 24-volt signal to the indoor blower relay and the blower stops.
- If LOW or HIGH fan speed is manually selected the fan will continue to blow.

Heating Cycle

- Set the thermostat for Heating
- If applicable the motorized valve opens as long as the thermostat calls for Heating.
- This sends a 24-volt signal to the terminal to the compressor contactor and the compressor starts.
- At the same time a 24-volt signal flows through the fan relay and the blower starts in HIGH speed, if the unit is in Auto Fan Mode. If the unit is in manual mode, set by the user, then the fan continuously blows in the user set speed.
- If in Auto Fan Mode, once the thermostat is within 2 degrees of set point, the fan drops to LOW speed.
- Once the thermostat is satisfied, it sends a 24-volt signal to the compressor contactor and compressor turns OFF.
- If in Auto Fan Mode, this ends the 24-volt signal to the indoor blower relay and the blower stops.
- If LOW or HIGH fan speed is manually selected the fan will continue to blow.

Maintenance

Your ICE AIR unit is designed to provide many years of efficient, trouble-free comfort conditioning service. To ensure equipment longevity and efficiency, please make sure that the following simple maintenance procedures are followed. This manual assumes that your unit has been installed by a qualified installation professional, and is operating properly prior to maintenance service.

Have your unit periodically inspected by a properly trained service professional or building maintenance staff person. The unit should be checked for the safe and proper functioning of all of its systems at least once a year. The following recommended maintenance procedures should be carried out only by trained personnel with strict adherence to the Safety Guidelines outlined at the beginning of this manual. These procedures **MUST** be followed to ensure your safety and the safety of the person maintaining the equipment!

Indoor Air Filter

It is recommended that you clean the indoor air filter after every 350 to 400 hours of unit operation – more frequently if the unit is running in an environment of high dust, pet dander or other pollutants in the indoor atmosphere.

Condensate Drain Pan and Drain Hoses

Check the unit condensate drain pan and drain hoses annually to ensure proper condensate drainage. If any foreign matter build-up in the drain pan is found, clean the drain pan and drain hoses – frequency of cleaning depends on the level of dirt and pollutants that may be present in the indoor environment.

Evaporator Coil

Check and clean (if necessary) the unit evaporator coil annually.

Evaporator Motor and Blower Assembly

Check and clean for dust and dirt build up as necessary.

Compressor

Annual check should be performed to detect potential problems.

Condenser (Water Heat Exchanger)

Water coil maintenance is not required. If the unit installation is located in a system with water problem history, it is best to establish a periodic maintenance program. It is the building's responsibility to maintain a water system that should provide your unit with treated and filtered water to keep water flowing freely through your equipment.

With these simple maintenance procedures carried out on a proper maintenance schedule, your unit should provide many

years of trouble-free service. The procedures are covered in greater detail on the following pages and should be implemented by trained personnel. But there are certain items that you, the apartment owner or tenant, can do to ensure proper unit function:

- Keep the area around your unit clear of objects that may block air flow into the unit – furniture, carpets and rugs, etc. may restrict air movement.
- Keep the top of your cabinet free of objects that may block air flow out of the unit – plants, paperwork and books, etc. should not be placed on or above the discharge grille area.
- Keep drapes, blinds and other window treatments clear of the air discharge area – any blockage of discharge air will have a negative impact on the unit and on its ability to properly condition the room.

General Unit Inspection

Visually inspect unit at least once a month. Pay special attention to hose assemblies and connections. Repair any leaks and replace deteriorated hose immediately to avoid potential costly damage to your property due to component failure.

Roomside Component Cleaning

IMPORTANT: Power MUST be disconnected before carrying out any of the following cleaning!

To access the components within the chassis of the unit:

1. Unit must be in OFF Position.
2. Disconnect unit from power source.
3. Remove the unit front cover/access door by unscrewing the retaining screws that hold it in place. You will then have access to the unit components.

NOTE: Pictures of components and parts may vary depending on your model.

Air Filter



1. Remove Air Filter.
2. If reusable, wash Air Filter in warm water and biodegradable cleaner.
3. Rinse with clean water and allow to dry completely.
4. Replace Air Filter.
5. As an alternate cleaning method, the filter may be cleaned on both sides using a vacuum cleaner and a soft brush type attachment.
6. If your filter is disposable, replace with new filter.

IMPORTANT: Do not operate unit without filters.

Evaporator Coil



Check the coil for cleanliness and uniformity of fins. If the coil is dirty, vacuum clean with a soft brush attachment. This is the only form of cleaning that should be carried out within an apartment. If the coil requires additional cleaning, the unit must be removed and cleaned using compressed air and/or washed. These operations MUST be carried out in a facility properly equipped to handle this type of work in a safe and professional manner.

Evaporator Motor and Blower Assembly



If there is evidence of dirt or dust build-up in the evaporator motor or blowers, they should be cleaned either by vacuum cleaning (if working in an apartment) or by removing the unit to a workshop location and cleaning with compressed air.

▲ WARNING: Always obey safety guidelines for using compressed air in this latter case.

Your ICE AIR unit has permanently lubricated motor bearings that do not require additional lubrication. Blowers and motors are factory assembled for quiet performance – if there is any excessive noise and vibration from this assembly, it should be serviced by a qualified technician.

Condenser (Water Heat Exchanger)

Generally, if water flow exceeds 3 gpm per ton, the water velocities should keep your coil free of scaling of debris that could lead to erosion and fouling.

Troubleshooting

IMPORTANT: It is not the intent of this maintenance manual to resolve any problems with the operation of your ICE AIR unit. Please contact a trained servicer or building maintenance staff immediately if your unit fails to perform properly.

1. Contact a trained service technician to conduct full unit diagnostics and repair to equipment.
2. Record any unit that does not operate noting the unit serial number on your report.

If unit is not operating, conduct the following checks:

1. Check the electrical connections.
2. Check the voltage and current against the electrical specifications on the unit nameplate.
3. Look for wiring errors. Check for loose screw connections in both line and low voltage terminals.
4. Check the water supply piping for proper water connection.
5. Check for dirty filters.
6. Check indoor fan for proper operation.
7. Check that unit did not cycle off due to improper thermostat settings.
8. Check for fault codes on the control board – consult the Board Troubleshooting Table.

⚠️ RECOGNIZE THIS SYMBOL AS A SAFETY PRECAUTION.

⚠️ WARNING: ICE AIR will not be responsible for any injury or property damage arising from improper service or service procedures. If you install or perform service on this unit, you assume responsibility for any personal injury or property damage which may result. Many jurisdictions require a license to install or service heating and air conditioning equipment.

⚠️ WARNING HIGH VOLTAGE: Disconnect all power before servicing or installing unit. Multiple power sources may be present. Failure to do so may cause property damage, personal injury or death.

Board Troubleshooting Table

WSHP Board ELA-8843/9830 Error Codes (VA.7 and up)	Board LED Code			Troubleshoot Guide
	Yellow	Green	Red	
Normal	OFF	ON	OFF	Normal Operation
High Pressure	OFF	OFF	FLASH	Low/no water flow, dirty coaxial coil, cap tube blockage, entering water temp is too high
Low Pressure	FLASH	OFF	OFF	Low charge, dirty filter, dirty evaporator coil
Evaporator Too Cold	FLASH	OFF	FLASH	Dirty filter, dirty evaporator coil, fan motor failure, low gas
Coaxial Winter Protection	FLASH	ON	OFF	Water too cold during off mode
Temperature Probe Failure	OFF	FLASH	OFF	Loose/disconnected probe wire, bad probe
High/Low Voltage	OFF	OFF	ON	Site voltage, bad transformer
Condensate Overflow	ON	OFF	OFF	Clogged condensate drainage
Coaxial Water Too Cold	ON	OFF	FLASH	Water too cold during on mode, low gas

Precautions and preparations listed are for general knowledge and to define basic guidelines. Local codes and existing practices should be observed and preformed by a professional. Due to ICE AIRs ongoing product development programs, the information in this document is subject to change without notice.



Notes or Technical Comments

Precautions and preparations listed are for general knowledge and to define basic guidelines. Local codes and existing practices should be observed and performed by a professional.
Due to ICE AIRs ongoing product development programs, the information in this document is subject to change without notice.



Notes or Technical Comments

Precautions and preparations listed are for general knowledge and to define basic guidelines. Local codes and existing practices should be observed and performed by a professional.
Due to ICE AIRs ongoing product development programs, the information in this document is subject to change without notice.



Notes or Technical Comments

Precautions and preparations listed are for general knowledge and to define basic guidelines. Local codes and existing practices should be observed and preformed by a professional.
Due to ICE AIRs ongoing product development programs, the information in this document is subject to change without notice.



Limited Warranty

Twelve (12) Month Warranty of ICE AIR units – ICE AIR, LLC, herein referred to as “ICE AIR,” warrants to the original owner that the entire unit is free from defects in material and workmanship for a period of twelve (12) months from the date of delivery. Any part of portion thereof which becomes defective under normal use during the period of this warranty will be repaired or replaced provided ICE AIRs examination shall prove to its satisfaction that the part was or became defective under normal use. ICE AIRs obligations under this warranty are limited to: (a) Repairing the defective part or (b) furnishing a replacement part provided the defective part is returned to the factory, without shipping damage, transporting charges prepaid. No reimbursement will be made for expenses incurred in making field adjustments or replacements unless specifically authorized in writing by the Company.

The Company is not obligated under this warranty for field labor such as service for inspection, removing, packing and/or reinstalling water source unit, nor for the return transportation charges.

OPTIONAL Extended Refrigeration Circuit Warranty

The Optional Extended Refrigeration Circuit Warranty MUST be purchased from ICE AIR within thirty (30) days from date of delivery to be valid. The hermetically sealed refrigeration circuit (consisting of the motor, compressor assembly, evaporator coil, coaxial/condenser coil and interconnecting tubing) is warranted to the original owner for four additional years from date of the expiration of the Twelve Month Warranty. Components under this warranty will be supplied at ICE AIRs expense provided the failed component is returned to the factory. This optional warranty does not include any other parts of the equipment such as fans, fan motors, controls, cabinet parts, electrical relays, capacitors, protective devices, or wiring. ICE AIR is not obligated under this warranty for field labor such as service for inspection, removing, packing, and/or reinstalling the refrigeration circuit, nor for return transportation charges. ICE AIR reserves the right to make a handling and inspection charge in the case of parts or equipment improperly returned as defective and/or as being in warranty.

To obtain assistance under the parts warranty or to purchase the optional extended warranty, simply contact ICE AIR Customer Service at 80 Hartford Avenue, Mount Vernon, New York 10553. Telephone **914-668-4700**.

The Twelve Month and the OPTIONAL Extended Refrigeration Circuit Warranty (which must be purchased separately) constitute the buyer’s sole remedy. They are given in lieu of all other warranties. There is no implied warranty of merchant-ability or fitness for a particular purpose. In no event and under no circumstance shall ICE AIR be liable for incidental or consequential damages, whether the theory is breach of this or any warranty, negligence, or strict tort.

No person (including any agent, salesman, dealer or distributor) has authority to expand ICE AIRs obligation beyond the terms of these express warranties, or to state that the performance of the product is other than that published by ICE AIR.

General Conditions

The above warranties are void if ICE AIRs equipment has been damaged, misused, subjected to abnormal use or service or its serial number has been altered, defaced, or removed, or payment for the equipment is in default. ICE AIR is not responsible for service to correct conditions due to misapplication, improper installation, inadequate wiring, incorrect voltage conditions or unauthorized opening of the refrigeration circuit, nor for consequential damages. In case ICE AIRs equipment is installed in conjunction with cabinets, grills, louvers, controls or other parts manufactured by others, these warranties shall apply only to ICE AIRs manufactured portion of the equipment. The conditions of the standard warranty plan are effective for 18 months from TCO. ICE AIR reserves the right to make a handling and inspection charge in the case of parts or equipment improperly returned as defective and/or as being warranty.

Important

The following are the responsibility of the user. They are not manufacturing defects, and are therefore not included in the warranty plan.

- 1) Failure of unit to operate satisfactorily due to improper amount of air on evaporator coil or air supply to air cooled condensers.
- 2) Damage to unit or unsatisfactorily operation due to improper cleaning of evaporator coil or use of unit in corrosive atmosphere locations such as chemical plants, refineries, or salt spray areas.
- 3) Damage to unit from unsatisfactory operation due to blown fuses, inadequate or interrupted electrical service, use of improper electrical protective devices or operation of unit on power supply other than covered by nameplate rating of unit.
- 4) Damage due to failure to properly maintain unit.

- 5) Damage due to transportation or handling prior to and during installation.
- 6) Damage due to accident or from alteration, improper installation, tampering.
- 7) Filter cleaning or replacement.
- 8) Misapplication.

Check, Test and Start

Check, Test and Start of the air conditioners by an experienced person is the responsibility of the installing contractor. This consists of physically confronting each unit operating in both heating and cooling modes and correcting any minor deficiencies noted. After the equipment leaves the factory, it may become damaged or maladjusted during transportation or on the job. Sometimes wires are disconnected accidentally, or fan motors move on their bases due to rough handling, causing fans to strike; a component(s) may be inoperable. The correction of such conditions is part of the Check, Test and Start. Note that unless otherwise specifically agreed to in writing, ICE AIR includes no field labor, Check, Test, and Start (or the like) in the price of its equipment.

Installation

ICE AIR is not responsible for the design, execution and performance of the installation method or any of the accessory items used during installation such as seals, caulking, weatherproofing, supporting structures, attachment means, louvers and frames supplied by others.



80 Hartford Avenue, Mount Vernon, NY 10553
Tel: 877-ICE-AIR-1 (877-423-2471)
Fax: 914-668-5643
email: service@ice-air.com

www.ice-air.com

© 2017 by ICE AIR, LLC

ICE6064 0117