

PACKAGED TERMINAL AIR CONDITIONER (PTAC) CERTIFIED DRAWING

DWG. NO.

 Submittal Template RSNUv2
REV. -

PROJECT			DATE		BY		TG		REVISIONS							
PURCHASER			P.O. #		QTY		DATE		BY		DESCRIPTION					
ARCHITECT			SHIP DATE		SLEEVES											
ENGINEER					HTG COIL											
HVAC CONTR.					ENCLOSURE											
GEN. CONTR.					CHASSIS											
DESIGNATION	MODEL NUMBER	QTY	ENCLOSURE (1)		SLEEVE (2)		LOUVER (3)		HTG COIL (4)		MOTORIZED VALVE		HEAT STAT		HTG COIL FRAME	
			STD	SPCL	STD	SPCL	STD	SPCL	STEAM	HOT WATER	YES	NO	YES	NO	YES	NO
A																
B																
C																
TOTAL																

UNIT SPECIFICATIONS+

GENERAL NOTES:

- ROOM ENCLOSURE IS FURNITURE TYPE PAINT-GRIP STEEL.
- WALL SLEEVE IS #18 GAUGE GALVANIZED STEEL.
- LOUVER IS EXTRUDED ALUMINUM, WITH CLEAR ANODIZED FINISH.
- IT IS RECOMMENDED THAT THE ELECTRICAL OUTLET IS INSTALLED OPPOSITE TO THE HEATING RISERS.
- N.Y.C. DEPARTMENT OF BUILDINGS ACCEPTED. MEA 250-93-E.-VOL. II
- HEATING COIL QUANTITY AND BREAKDOWN BY MECHANICAL CONTRACTOR.
- SEE ACCOMPANYING DRAWINGS FOR UNIT CONFIGURATION.
- STANDARD ROOM COLOR ENCLOSURE TO BE "ANTIQUE WHITE"
- PROVIDE LOUVERS FOR ALL MASONRY OPENING. LOUVERS FOR PANEL WALL OPENINGS PROVIDED BY OTHERS.

SERIES MODEL #	5RSNU07	5RSNU09	8RSNU09	5RSNU13	8RSNU13	8RSNU15	8RSNU18
COOLING CAPACITY*	7,700	9,700	9,700	12,800	12,800	14,400	16,400
EER	12	12	12	11.4	11.4	10.5	10.3
HEATING CAPACITY (HOT WATER)**	16,500	16,500	16,500	16,500	16,500	19,400	19,400
HEATING CAPACITY (STEAM)***	18,700	18,700	18,700	18,700	18,700	20,200	20,200
VOLTAGE	115	115	208/230	115	208/230	208/230	208/230
AMPERAGE	5.5	7.1	3.9	9.9	5.5	6.5	7.7
WATTS	633	808	808	1,123	1,123	1,333	1,592
CFM ROOM AIR HIGH	380	380	380	400	400	450	540
CFM ROOM AIR LOW	300	300	300	350	350	380	450
CFM OUTSIDE AIR (4)	60	60	60	60	60	60	60
CFM X OUTSIDE AIR (5)	110	110	110	110	110	110	110
WEIGHT NET/SHIP	113/129	117/133	117/133	124/138	124/138	132/148	141/157

CUSTOM NOTES:

I:

SPECIFICATION NOTES:

- * = BTUH @ 80°F. DB/67 °F. WB INDOORS; 95 °F. DB OUTDOORS.
- **= BTUH @ 200 °F. E.W.T.; 65 °F. E.A.T. & 2 G.P.M. FLOW RATE.
- *** = BTUH @ 2 PSIG STEAM & 65 °F. E.A.T.
- OPTIONAL CAN BE MOTORIZED
- OPTIONAL CAN BE MOTORIZED
- ALL UNITS ARE WITH R410A REFRIGERANT
- FOR CAPACITIES AT CONDITIONS OTHER THAN THOSE SHOWN IN NOTES 1-3 ABOVE USE GRAPHICS BELOW.

PERFORMANCE DATA

COOLING CAPACITY CORRECTION FACTORS

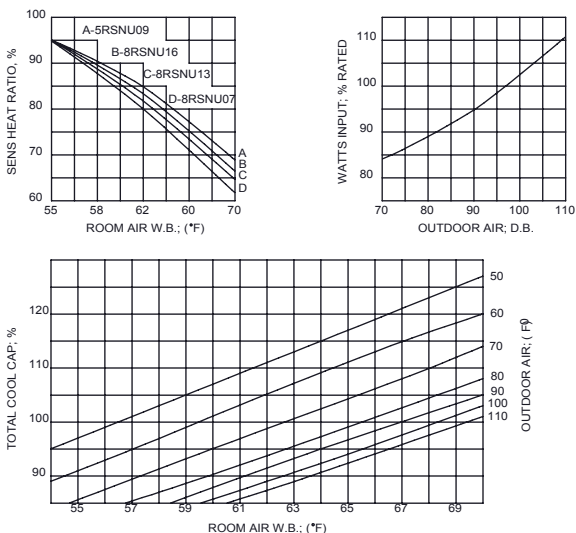

HEATING CAPACITY CORRECTION FACTORS

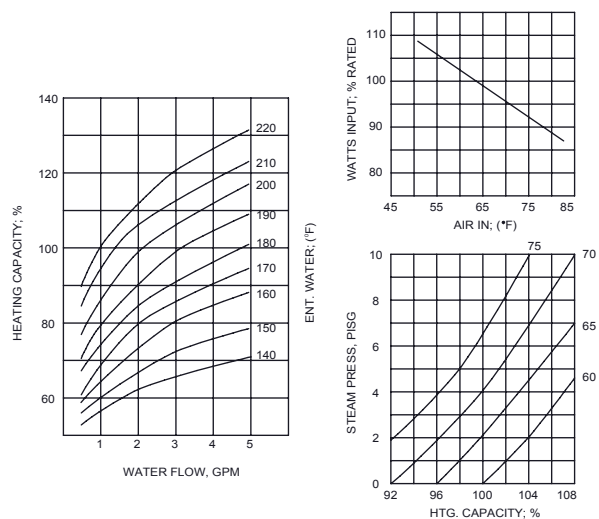

REVISIONS			
REV.	DESCRIPTION	BY	DATE

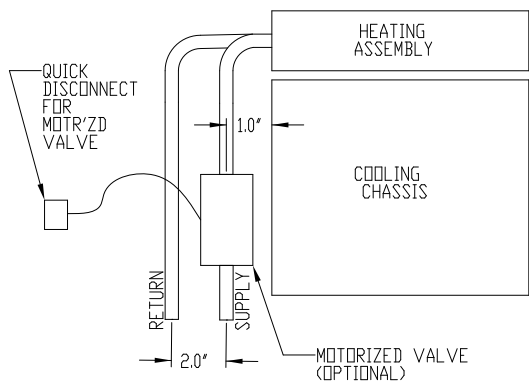

DETAIL 'A'
LEFT HAND SHOWN
RIGHT HAND OPPOSITE
INSTALLATION BY OTHERS

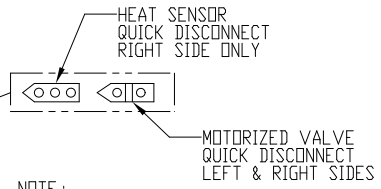
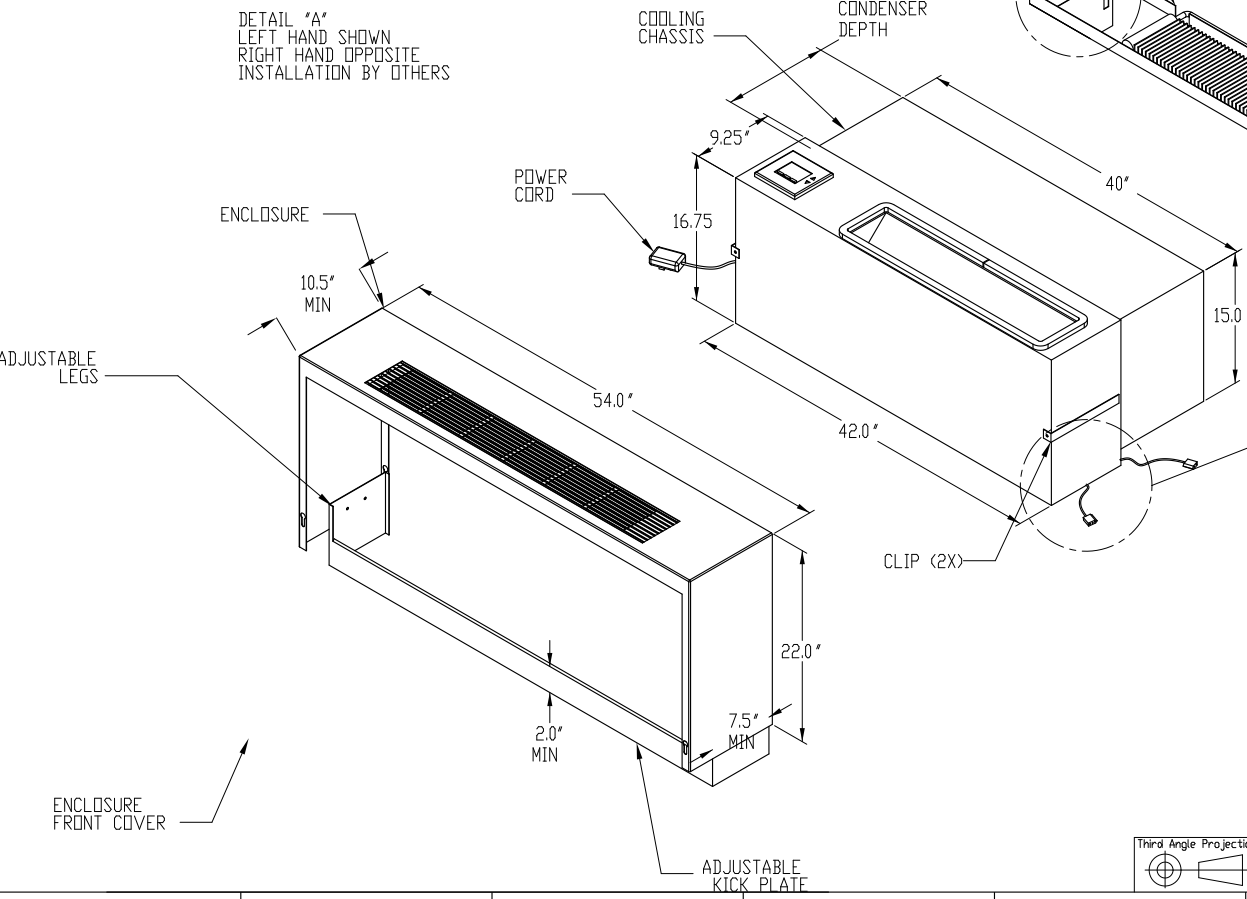
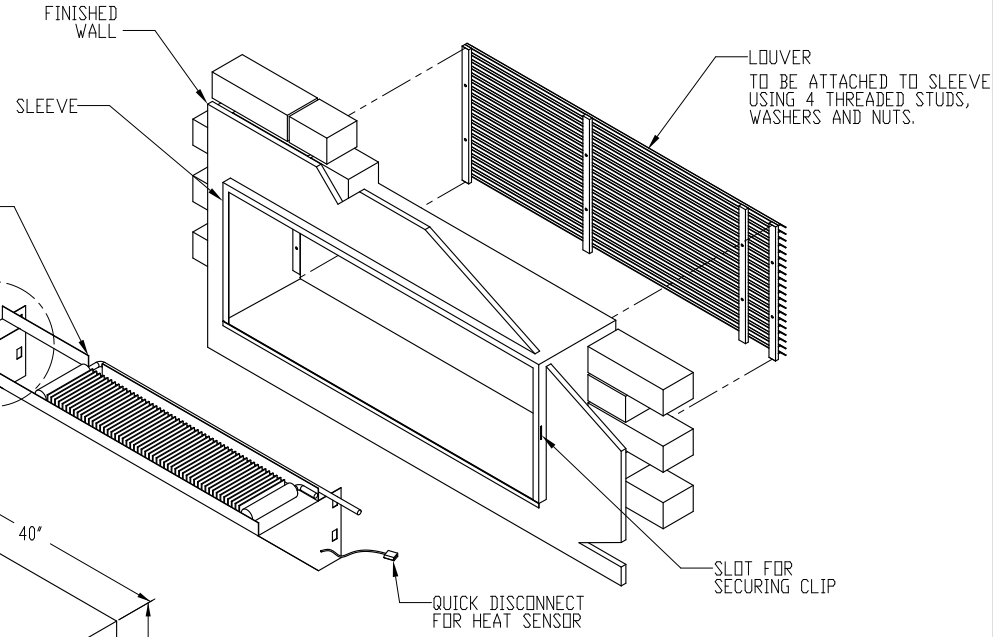

NOTE:
TO REMOVE THE COOLING CHASSIS FROM SLEEVE, DISCONNECT POWER CORD FROM RECEPTACLE, AND SEPARATE QUICK DISCONNECTS FROM HEAT SENSOR AND MOTORIZED VALVE.

THIS ALLOWS THE CHASSIS TO SLIDE OUT OF THE WALL SLEEVE WITHOUT DISTURBING THE PERMANENTLY INSTALLED HEATING ASSEMBLY.

MATERIAL:	ICE-AIR LLC. 80 HARTFORD AVENUE MOUNT VERNON, NY 10553		
WEIGHT (LBS):	TITLE: STANDARD RSNU UNIT INSTALLATION		
FINISH:	MODEL BY:	DATE:	DWG. NO.:
UNLESS OTHERWISE SPECIFIED: DIMENSIONS ARE IN INCHES	DRAWING BY:	DATE:	
TOLERANCES: FRACTIONAL ± 1/32 ANGULAR: MACH ± ° BEND ± 1° TWO PLACE DECIMAL ± .03 THREE PLACE DECIMAL ± .015	SIZE B	SCALE: NONE DO NOT SCALE DRAWING	SHEET 1 OF 1
			REV A

Third Angle Projection
PROPRIETARY AND CONFIDENTIAL
THIS DRAWING IS PROPERTY OF
ICE-AIR, LLC IT MAY NOT BE
REPRODUCED, COPIED, OR
OTHERWISE CLIPPED WITHOUT
PRIOR WRITTEN AUTHORIZATION.

8 7 6 5 4 3 2 1

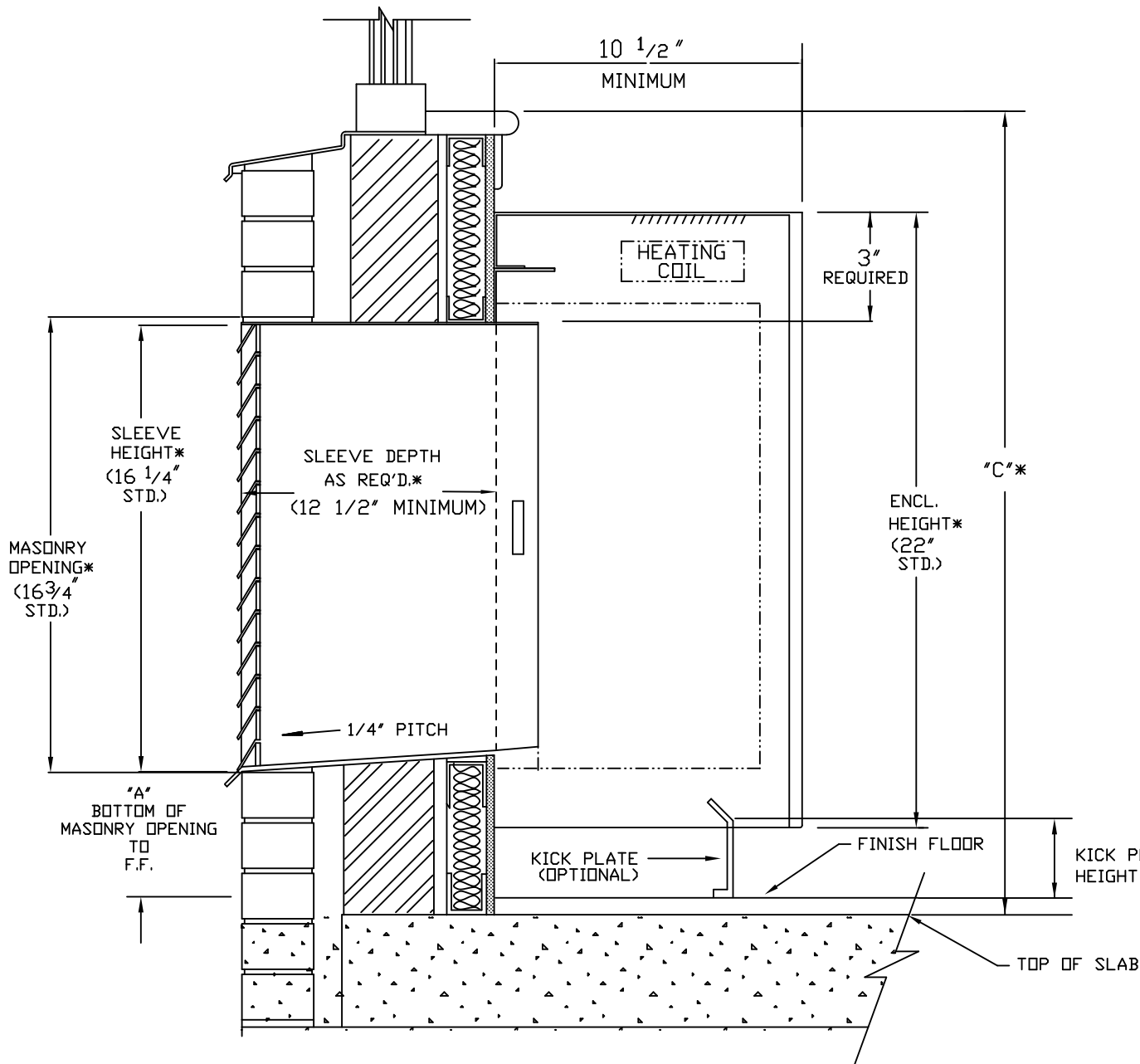

**** NOTES ****

- 1) WALL SLEEVE DIMENSION:
(RSNU) = 42"W x 16-1/4"H
MINIMUM SLEEVE DEPTH: 12-1/2"
- 2) ENCLOSURE DIMENSION: TYPICAL*
10-1/2"D x 22"H x 54"W
- 3) KICK PLATE = B. VARIES ("A" - 2 1/2")
WITH ±1" ADJUSTMENT.
- 4) 4" ABOVE TOP OF SLEEVE ON ROOMSIDE
MUST BE KEPT CLEAR FOR MOUNTING
OF HEATING COIL AND ENCLOSURE.
- 5) WHEN "A", BOTTOM OF SLEEVE TO FINISHED
FLOOR, MEASURES BETWEEN 2-3/4" TO 4-1/2,"
THIS NECESSITATES ORDERING A FRONT INTAKE
ENCLOSURE AND CHASSIS AS OPPOSED TO A
BOTTOM INTAKE.
- 6) DIMENSIONS "A" AND "C", PROVIDED FOR EACH
FLOOR, DETERMINE ENCLOSURE HEIGHT

* DETAILS TO BE PROVIDED FOR EACH FLOOR

ICE-AIR LLC.					
RSNU STANDARD					
TITLE TYP. PTAC @ MASONRY					
SCALE	N.T.S.	DR. BY	L.R.	DRG. NO.	REV.
DATE	01/15/10	CHK. BY			

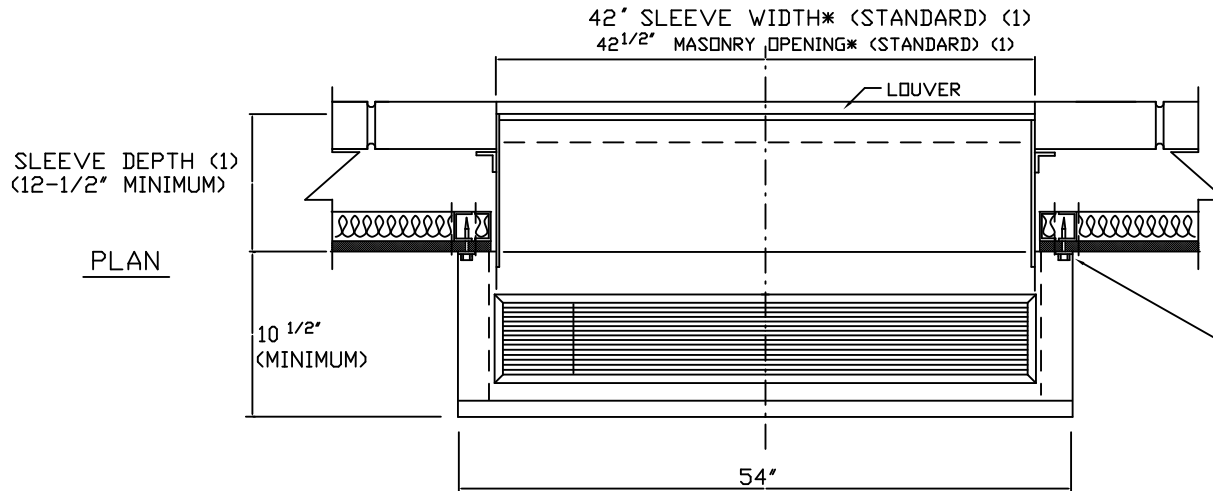

NOTES

- (1) DETAILS TO BE PROVIDED BY GC FOR EACH FLOOR
- (2) PROVIDED LOUVER WILL HAVE AN AREA OF MINIMUM 60% FREE AIR FLOW
- (3) DETAILS TO BE PROVIDED FOR EACH FLOOR
 "A" IS BOTTOM OF SLEEVE TO FINISHED FLOOR
 "B" IS KICK PLATE HEIGHT WITH +/- 1" ADJ.
 "B" = "A" - 2 1/2"
 WHEN "A", BOTTOM OF SLEEVE TO FINISHED FLOOR, MEASURES BETWEEN 2-3/4" TO 4-1/2" IT IS ADVISED TO ORDER A FRONT INTAKE ENCLOSURE AND CHASSIS AS OPPOSED TO A REGULAR BOTTOM INTAKE.

PROVIDE METAL GYP. BD. STUDS FOR ENCLOSURE ATTACHMENT (53" CENTER TO CENTER)

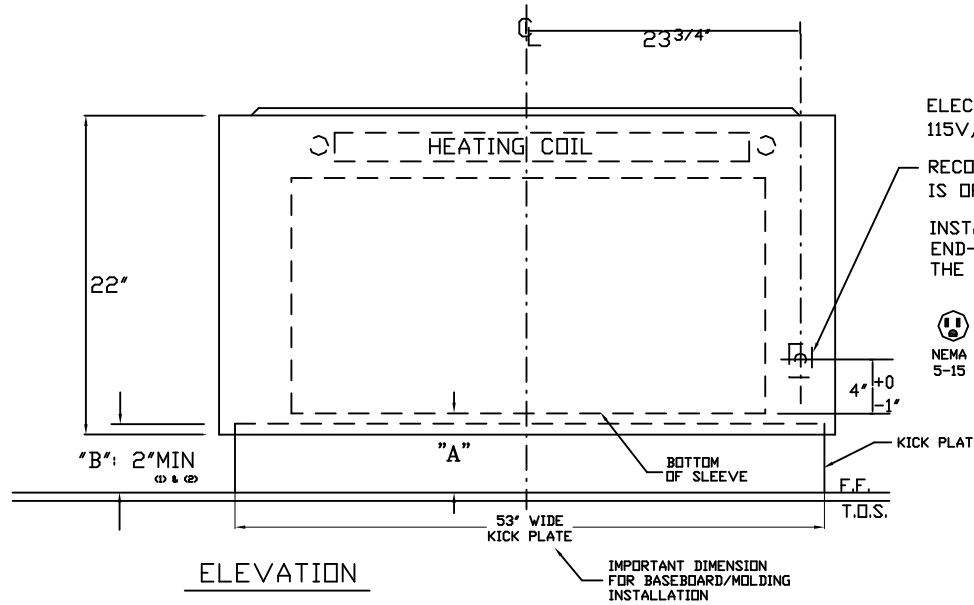

ELECTRIC OUTLET BY ELECTRICAL CONTRACTOR 115V, 15A OR 208V, 15A AS REQUIRED.

RECOMMENDED LOCATION OF ELECTRICAL OUTLET IS OPPOSITE HEATING RISERS

INSTALL THE ELECTRICAL OUTLET WHERE THE END-USER CAN EASILY CONNECT/DISCONNECT THE POWER CORD PLUG.

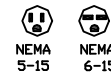

NO.	REVISIONS	DATE	BY
ICE-AIR LLC			
RSNU STANDARD			
TITLE			
TYP. PTAC @ MASONRY WALL			
SCALE	N.T.S.	DR. BY	L.R.
DATE	01/15/10	CHK. BY	
DRG. NO.		REV.	

* ARCHITECT TO PROVIDE DETAILS FOR EACH FLOOR

NOTE (1):
PROVIDED LOUVER WILL HAVE AN AREA OF
60% MINIMUM FREE AIR

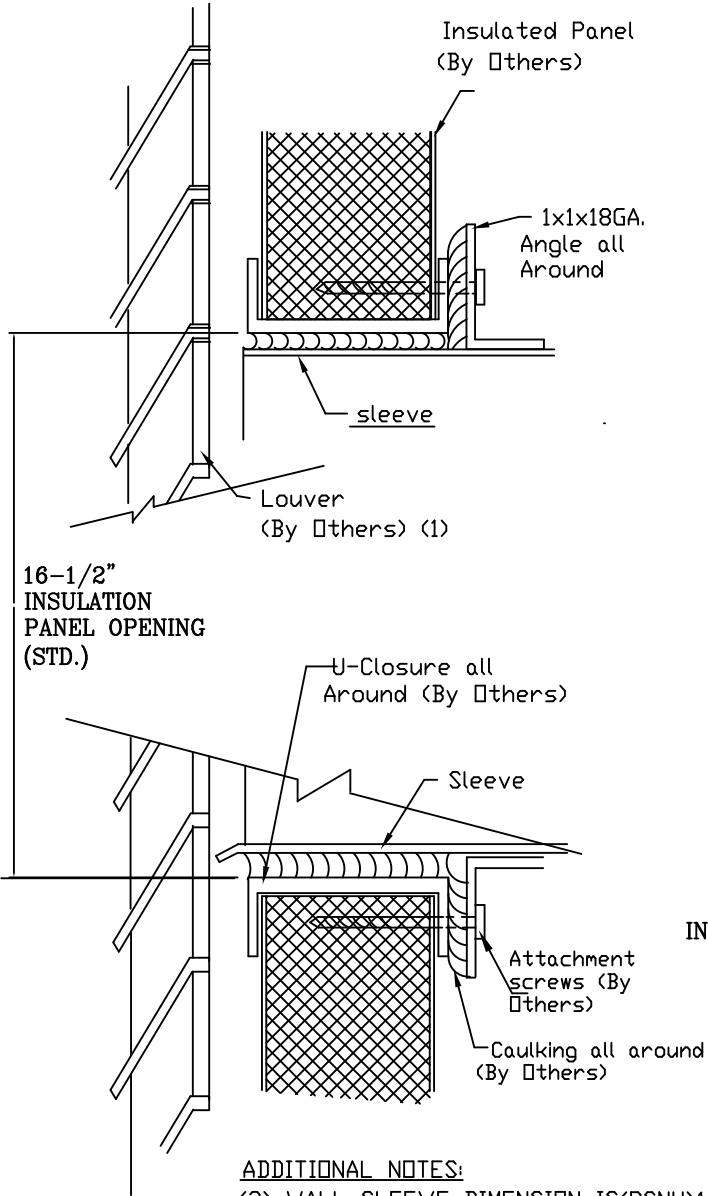

ADDITIONAL NOTES:

- (3) WALL SLEEVE DIMENSION IS (RSNU) 16'-1/4" H x 42" W
- (4) WHEN BOTTOM OF SLEEVE TO FINISHED FLOOR ("A") MEASURES BETWEEN 2^{3/4}" TO 4^{1/2}". THIS NECESSITATES ORDERING A FRONT INTAKE ENCLOSURE AND CHASSIS AS OPPOSED TO A BOTTOM INTAKE.

NOTE (2):
4" ABOVE TOP OF SLEEVE ON ROOMSIDE
MUST BE KEPT CLEAR FOR MOUNTING
OF HEATING COIL AND ENCLOSURE.

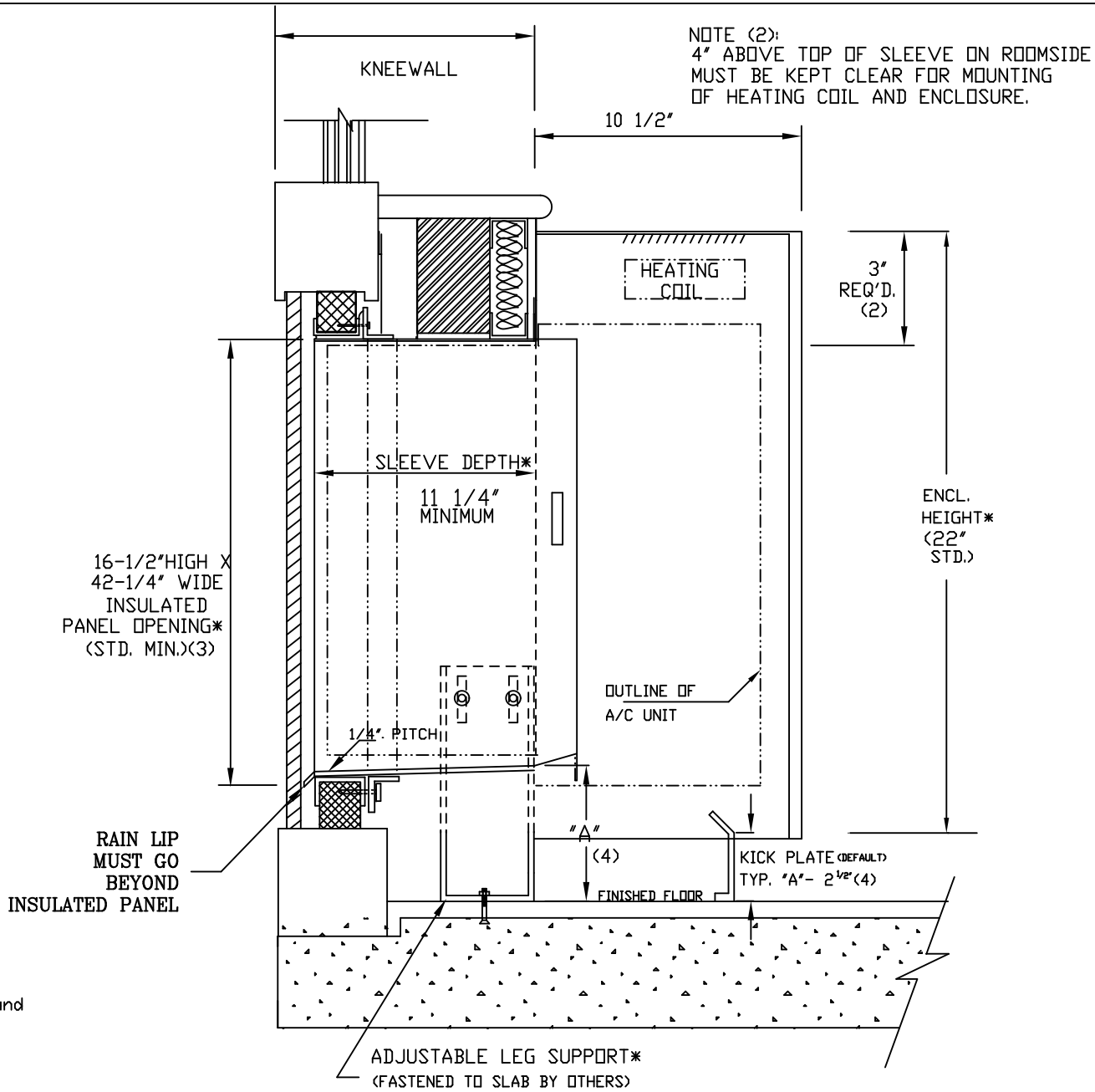

NO.	REVISIONS	DATE	BY
ICE-AIR LLC. RSNU STANDARD			
TITLE TYP. PTAC @ PANEL WALL			
SCALE N.T.S.	DR. BY L.R.	DRG. NO.	REV.
DATE 01/15/10			

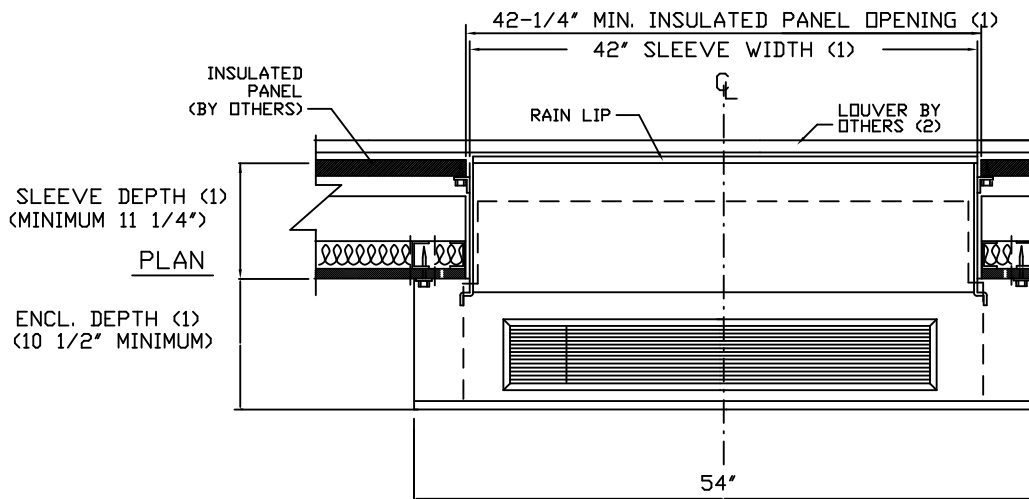

NOTES

- (1) DETAILS TO BE PROVIDED BY GC FOR EACH FLOOR
- (2) LOUVER MUST HAVE AN AREA OF MINIMUM 60% FREE AIR FLOW
- (3) DETAILS TO BE PROVIDED FOR EACH FLOOR
 "A" IS BOTTOM OF SLEEVE TO FINISHED FLOOR
 "B" IS KICK PLATE HEIGHT WITH +/- 1" ADJ.
 "B" = "A" - 2 1/2"
 WHEN "A", BOTTOM OF SLEEVE TO FINISHED FLOOR, MEASURES BETWEEN 2-3/4" TO 4-1/2" IT IS ADVISED TO ORDER A FRONT INTAKE ENCLOSURE AND CHASSIS AS OPPOSED TO A REGULAR BOTTOM INTAKE.

PROVIIDE METAL GYP. BD. STUDS FOR ENCLOSURE ATTACHMENT (53" CENTER TO CENTER)

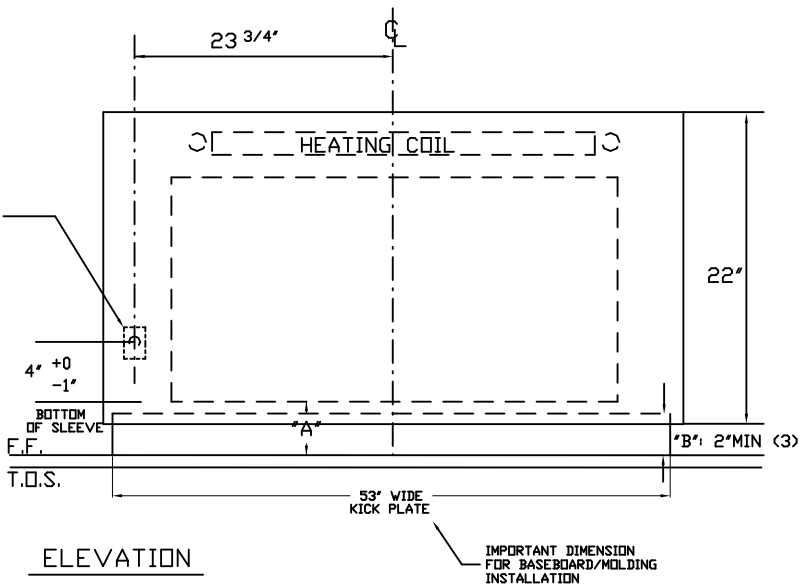

ELECTRIC OUTLET BY ELECTRICAL CONTRACTOR 115V, 15A OR 208V, 15A AS REQUIRED.
 RECOMMENDED LOCATION OF ELECTRICAL OULET IS OPPOSITE HEATING RISERS.
 INSTALL THE ELECTRICAL OUTLET WHERE THE END-USER CAN EASILY CONNECT/DISCONNECT THE POWER CORD PLUG.

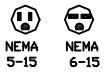

ELEVATION

NO.	REVISIONS	DATE	BY
ICE-AIR LLC			
TITLE RSNU STANDARD			
TYP. RSNU @ CURTAIN WALL			
SCALE	N.T.S.	DR. BY	L.R.
DATE	01/15/10	CHK. BY	
DRG. NO.			REV.

LEFT HAND COIL SHOWN BELOW
RIGHT HAND COIL OPPOSITE

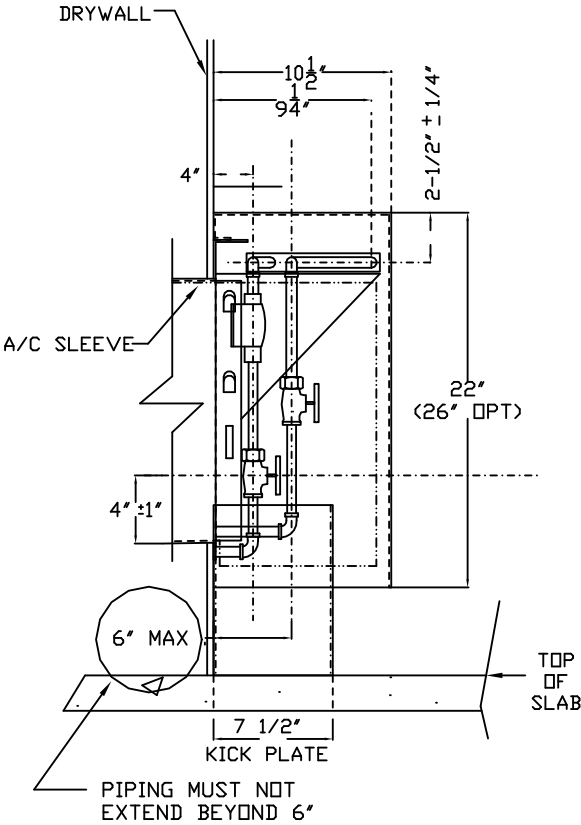

SIDEVIEW

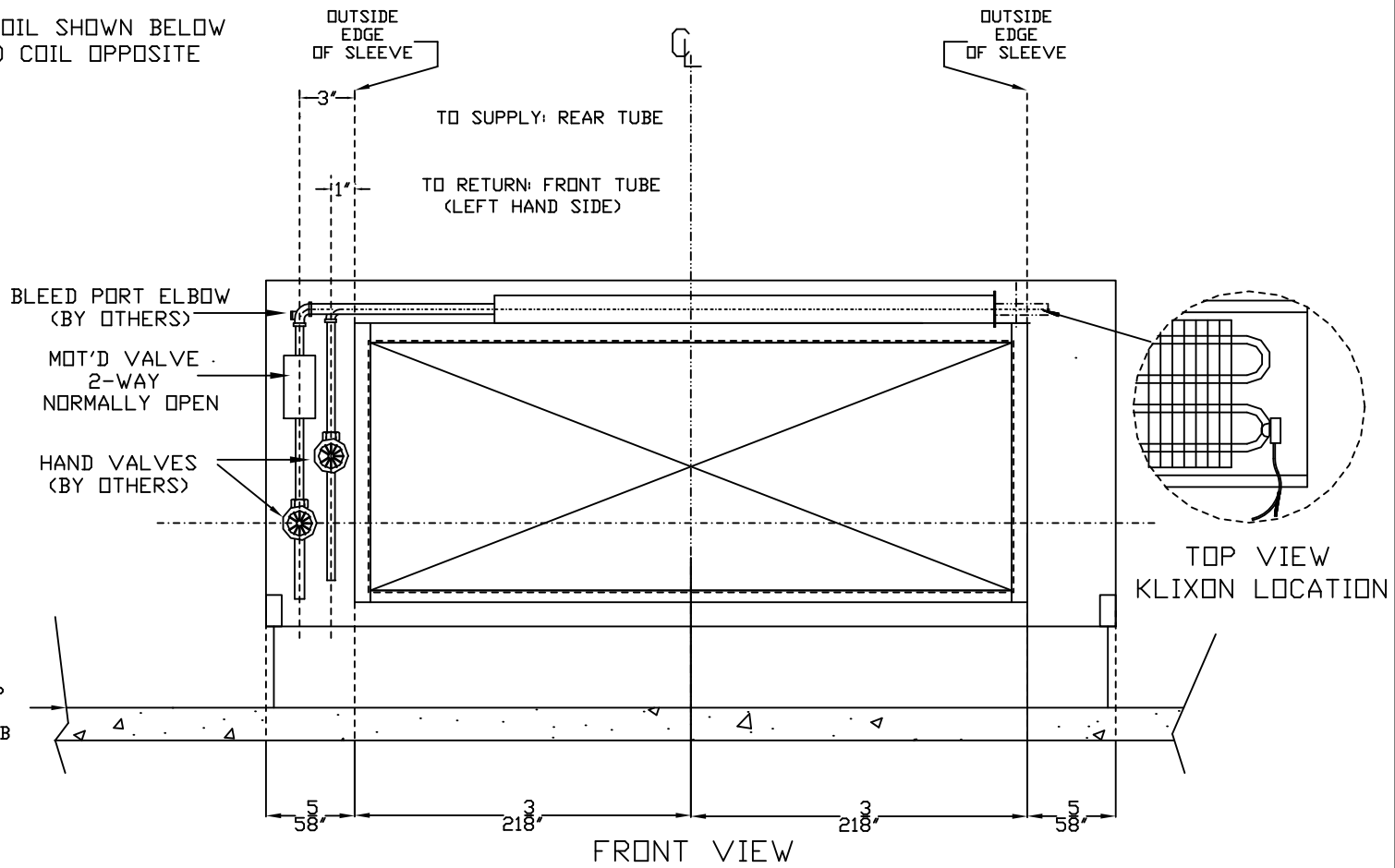

FRONT VIEW

**** NOTES ****

- 1) RECOMMENDED PIPING TO 5/8" O.D. HEATING COIL TUBE STUBS.
- 2) ICE-AIR SUPPLIES HEATING COIL ASSEMBLY & MOT. VALVE LOOSE.
- 3) MOTORIZED VALVE IS NORMALLY OPEN FOR HOT WATER SYSTEM UNLESS OTHERWISE SPECIFIED.

ICE-AIR LLC. 80 HARTFORD AVE. MOUNT VERNON, NY 10553			
CUSTOMER:			
TITLE: RSNU SERIES HOT WATER HEAT PIPING DIAGRAM (54")			
DATE:	DWG BY:	DWG #:	REV.
01/19/10	L.R.		

LEFT HAND COIL SHOWN BELOW
RIGHT HAND COIL OPPOSITE

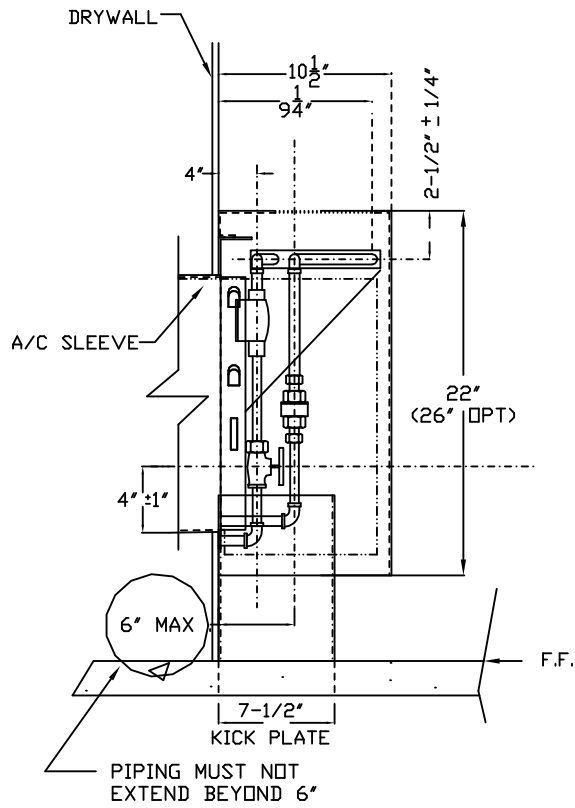

SIDEVIEW

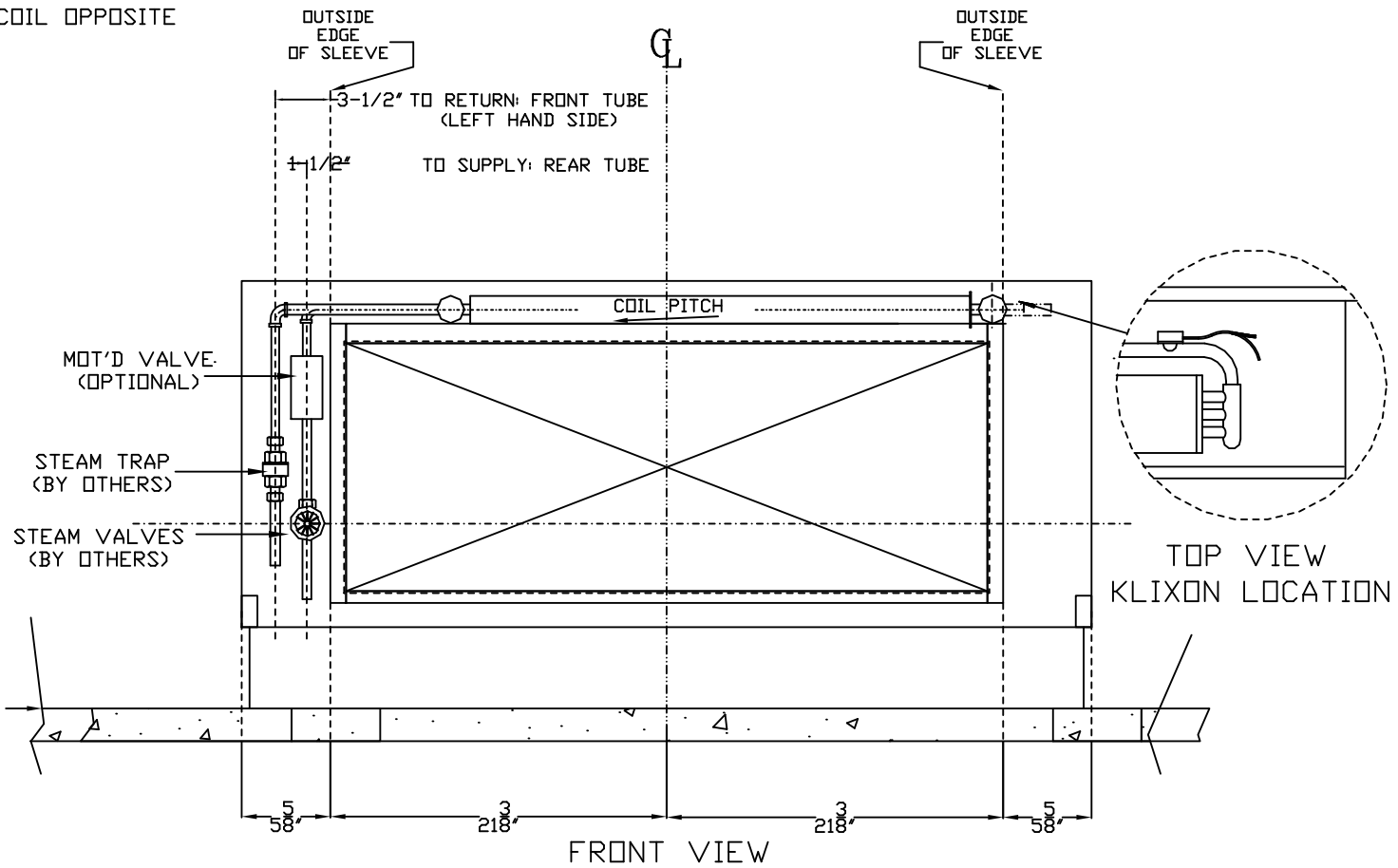

FRONT VIEW

**** NOTES ****

- 1) RECOMMENDED PIPING TO 5/8" O.D. HEATING COIL TUBE STUBS.
- 2) ICE-AIR SUPPLIES HEATING COIL ASSEMBLY & MOT. VALVE LOOSE.
- 3) MOTORIZED VALVE IS NORMALLY CLOSED FOR STEAM SYSTEM UNLESS OTHERWISE SPECIFIED.
- 4) COIL & TUBING MUST BE PITCHED FOR CONDENSATE RETURN.

ICE-AIR LLC. 80 HARTFORD AVE. MOUNT VERNON, NY 10553			
CUSTOMER:			
TITLE: RSNU SERIES STEAM HEAT PIPING DIAGRAM (54")			
DATE:	DWG BY:	DWG #:	REV.
01/19/10	LR		

PRODUCT SPECIFICATIONS
PACKAGED TERMINAL AIR CONDITIONER (PTAC)

ICE AIR HI SPEC™ UNITS
'RSNU' SERIES UNITS

1. Equipment: Provide "RSNU" Series Packaged Terminal Air Conditioners (PTACs), as manufactured by Ice Air, LLC.
2. Components: Air conditioner to consist of wall sleeve, exterior louver, heating coil assembly, cooling chassis and room enclosure. Units to operate at either 115 volt, 208 / 230 volt, or 265 or 277 volt, single phase, 60 hertz circuits.
3. Wall Sleeves: Wall sleeve exterior dimensions to be 42" wide x 16" high (RSCT Series), to comply with US DOE requirements for new construction PTACs. Smaller dimension wall sleeves are not acceptable under DOE regulations. Wall sleeve to be factory fabricated of 18 gauge galvanized steel and to be shipped with a mechanically-attached temporary coated cardboard filler panel at the exterior for weather protection. Cardboard filler panel to be removed prior to chassis and louver installation. Wall sleeve to have built-in pitch of at least ¼" and to be fabricated with an angled rain lip for proper drainage to the exterior of the building. Wall sleeves for masonry locations to be factory fabricated to match the full wall depth at each location; wall sleeves with field-installed extension pieces are not acceptable. Wall sleeves for panel wall locations are to be provided with optional adjustable-height support legs and galvanized steel sleeve angles to attach to the building panel wall system.
4. Louvers: Exterior louver to be horizontal, extruded aluminum blade-type construction with clear anodized (painted Duranar) finish. Louver to be supplied with stainless steel fastening hardware and must be capable of being installed from within the wall sleeve. Louvers at panel wall locations to be supplied by others.
5. Chassis: Cooling chassis to be a self-contained, slide-in assembly consisting of a sealed refrigerant system, evaporator and condenser sections with separate PSC motors (single motor units are not acceptable), manual (optional motorized) outside fresh air damper, unit mounted controls and line cord (junction box for 265 / 277 volt applications). Provide a permanent, washable aluminum mesh filter with each unit.
- 5a. Refrigeration System: Sealed refrigerant system to consist of high efficiency rotary compressor, copper tube / aluminum fin evaporator and condenser coils, refrigeration metering device consisting of a capillary

- tube expansion system and interconnecting tubing. System to be factory charged and sealed and capable of operating in the cooling mode to an outdoor ambient temperature of 35° F. All units to be manufactured with R410A Green refrigerant; units containing R22 or R407C refrigerant are not acceptable.
- 5b. Evaporator Section: Evaporator motor and tangential blower wheel to be mounted above the evaporator coil. Tangential blower wheel to be fabricated from aluminum and to be directly driven by a multi-speed PSC motor with built-in thermal overload protector. Evaporator section to contain an integral stamped and powder coated steel drain pan, draining into two 3/4" i.d. drain hoses (single drain units are not acceptable).
- 5c. Condenser Section: Condenser section to contain a separate PSC motor and metal propeller fan with an integral slinger ring. Condenser motor to cycle with compressor and to run during the cooling cycle only.
- 5d. Condensate Disposal: Condensate to drain from the indoor evaporator pan into the exterior galvanized steel condenser base pan through two 3/4" i.d. drain hoses. Condensate disposal to be accomplished by the entrainment of water particles in the condenser air stream and evaporation upon the hot condenser coil. No building condensate drain lines are to be required.
- 5e. Chassis Sheet Metal: Chassis sheet metal parts to be manufactured entirely of 18 gauge and 20 gauge galvanized steel. Chassis base pan to be powder coated inside and out to prevent corrosion of sheet metal pan. Chassis to be manufactured with an outsized indoor section that mates with the wall sleeve interior flanges and creates a positive weather seal using crushable pressure-sensitive foam tape, thereby preventing air and water infiltration. Chassis seal must be an integral part of unit construction, and use of attached sealing angles or channels is not acceptable.
- 5f. Unit Controls: Unit controls to include a digital controller with integral electronic thermostat. Controller to be seven-day programmable type (optional non-programmable). (Optional Manual Changeover (MCO) or remote wall mount thermostats are available. Include standard low-temperature control to activate motorized heating control valve below 45°F. interior room temperature, and Freezestat to be mounted on the evaporator coil only (condenser mounted freezestats are unacceptable) to provide true temperature readings.
- 5g. Manual Outside Air: Provide manual outside air damper with chassis mounted actuator. (Optional motorized or full time motorized fresh air dampers are available).

6. Heating Assembly (Hydronic Heat): Heating Assembly to consist of a snap-in galvanized steel cradle and heating coil, with optional (Normally Open) (Normally Closed) motorized heating control valve. Motorized valve to be provided with Molex-type pin connector for plug-in electrical connection to the chassis, and to be actuated by the unit thermostat. Heating coil to be fabricated of copper tubing, mechanically expanded into aluminum fins. (Steam coil to be headered type) (Hot water coil to be serpentine type.). Coils to be supplied either right- or left-handed in quantities specified in building plans. Entire heat assembly to permanently mount onto the wall sleeve horizontally above cooling chassis and to have proper pitch built into the cradle assembly to ensure correct drainage of condensate water towards the return line in steam systems. Supply of all required valves and fittings, other than the motorized valve, is by others. Motorized valve to be shipped loose for field installation (optional factory attachment to heat assembly).
7. Room Enclosure (Cabinet): Room enclosure to be (flat top) (slope top) type and to be fabricated of 18 gauge galvanized paint grip furniture steel. Enclosure front cover to be fabricated from 20 gauge galvanized steel and to be removable without the use of tools.. Enclosure to be finished in (Antique White) (Arctic White) baked powder coat finish. Room enclosure to mount to wall sleeve. Provide concealed flanges with clearance holes as an alternate means of enclosure attachment by fastening directly to the interior wall. Enclosure kick plate to be vertically adjustable.
8. Warranty and Code Compliance: Unit to be guaranteed free of defects in material and workmanship for one year from date of delivery. Provide (OPTIONAL) additional 2nd through 5th year compressor parts warranty. Units to be ETL listed for safety in the United States and Canada, to have New York City MEA and BEC approvals, to be in compliance with all local, state and federal energy efficiency and building codes and to be tested in accordance with current ARI standards.