

PACKAGED TERMINAL AIR CONDITIONER (PTAC) CERTIFIED DRAWING

DWG. NO.

Submittal Template RSEA

REV. -

PROJECT	DATE	BY	REVISIONS
PURCHASER	P.O. #	QTY	DESCRIPTION
ARCHITECT	SHIP DATE	SLEEVES	
ENGINEER		HTG COIL	
HVAC CONTR.		ENCLOSURE	
GEN. CONTR.		CHASSIS	

DESIGNATION	MODEL NUMBER	QTY	ENCLOSURE (1)		SLEEVE (2)		LOUVER (3)		HTG COIL (4)		MOTORIZED VALVE		HEAT STAT		HTG COIL FRAME	
			STD	SPCL	STD	SPCL	STD	SPCL	STEAM	HOT WATER	YES	NO	YES	NO	YES	NO
A																
B																
C																
TOTAL																

UNIT SPECIFICATIONS+

SERIES MODEL #	5RSEA07	5RSEA09	5RSEA13	8RSEA09	8RSEA13	8RSEA18	7RSEA09	7RSEA13
COOLING CAPACITY*	7,250	9,000	12,100	9,300	12,150	16,300	9,000	12,100
EER	9.4	9.1	8.4	8.95	8.35	7.7	9.1	8.4
HEATING CAPACITY (HOT WATER)**	16,500	16,500	16,500	16,500	16,500	19,400	16,500	16,500
HEATING CAPACITY (STEAM)***	15,100	15,100	15,100	15,100	15,100	18,100	15,100	15,100
ELECTRIC HEATING MAX. (KW)	1.5	1.5	1.5	4.3	4.3	4.3	3.5	3.5
VOLTAGE	115	115	115	208/230	208/230	208/230	277	277
AMPERAGE	6.7	8.6	12.5	5.0	7.0	10.2	3.6	5.2
WATTS	771	989	1,440	1,039	1,455	2,117	989	1,440
CFM ROOM AIR HIGH	370	370	370	370	370	430	370	370
CFM ROOM AIR LOW	260	260	260	260	260	260	260	260
CFM OUTSIDE AIR	60	60	60	60	60	60	60	60
CFM X OUTSIDE AIR	110	110	110	110	110	110	110	110
WEIGHT NET/SHIP	120/136	120/136	120/136	120/136	120/136	130/146	120/136	120/136

GENERAL NOTES:

- ROOM ENCLOSURE IS FURNITURE TYPE PAINT-GRIP STEEL.
- WALL SLEEVE IS #18 GAUGE GALVANIZED STEEL.
- LOUVER IS EXTRUDED ALUMINUM, WITH CLEAR ANODIZED FINISH.
- IT IS RECOMMENDED THAT THE ELECTRICAL OUTLET IS INSTALLED OPPOSITE TO THE HEATING RISERS.
- N.Y.C. DEPARTMENT OF BUILDINGS ACCEPTED. MEA 250-93-E.-VOL. II
- HEATING COIL QUANTITY AND BREAKDOWN BY MECHANICAL CONTRACTOR.
- SEE ACCOMPANYING DRAWINGS FOR UNIT CONFIGURATION.
- STANDARD ROOM COLOR ENCLOSURE TO BE "ANTIQUE WHITE"
- PROVIDE LOUVERS FOR ALL MASONRY OPENINGS. LOUVERS FOR PANEL WALL OPENINGS PROVIDED BY OTHERS.

CUSTOM NOTES:

1:

SPECIFICATION NOTES:

- * = BTUH @ 80°F. DB/67 °F. WB INDOORS; 95 °F. DB OUTDOORS.
- ** = BTUH @ 200 °F. E.W.T.; 65 °F. E.A.T. & 2 G.P.M. FLOW RATE.
- *** = BTUH @ 2 PSIG STEAM & 65 °F. E.A.T.
- FOR CAPACITIES AT CONDITIONS OTHER THAN THOSE SHOWN IN NOTES 1-3 ABOVE USE GRAPHICS BELOW.

PERFORMANCE DATA

COOLING CAPACITY CORRECTION FACTORS

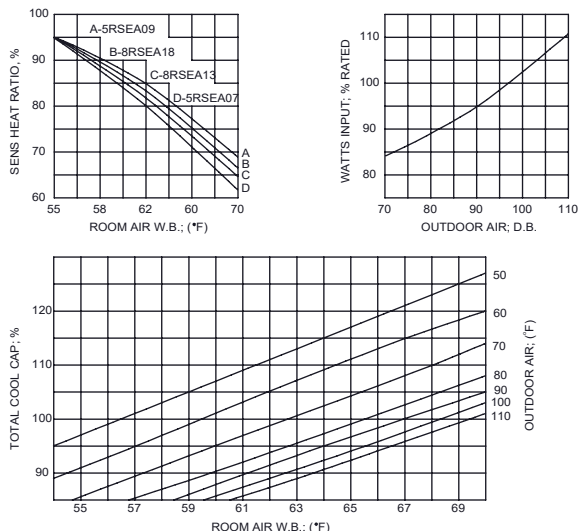

HEATING CAPACITY CORRECTION FACTORS

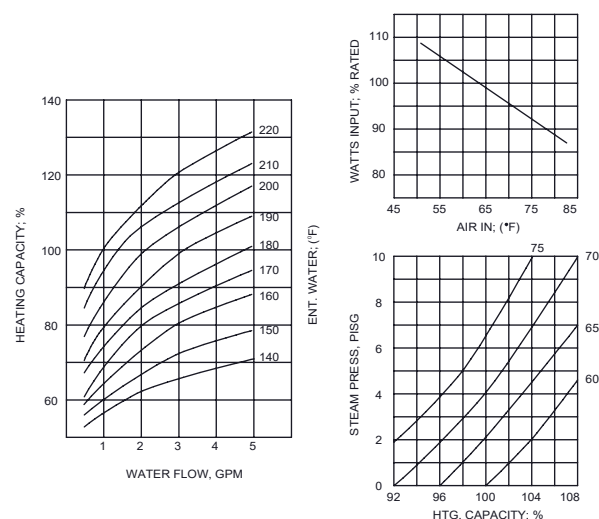

APA-8448

REVISIONS			
REV.	DESCRIPTION	BY	DATE
B	Dimensions Adjusted	LR	4/8/2008
C			4/22/2013
D			10/10/2018

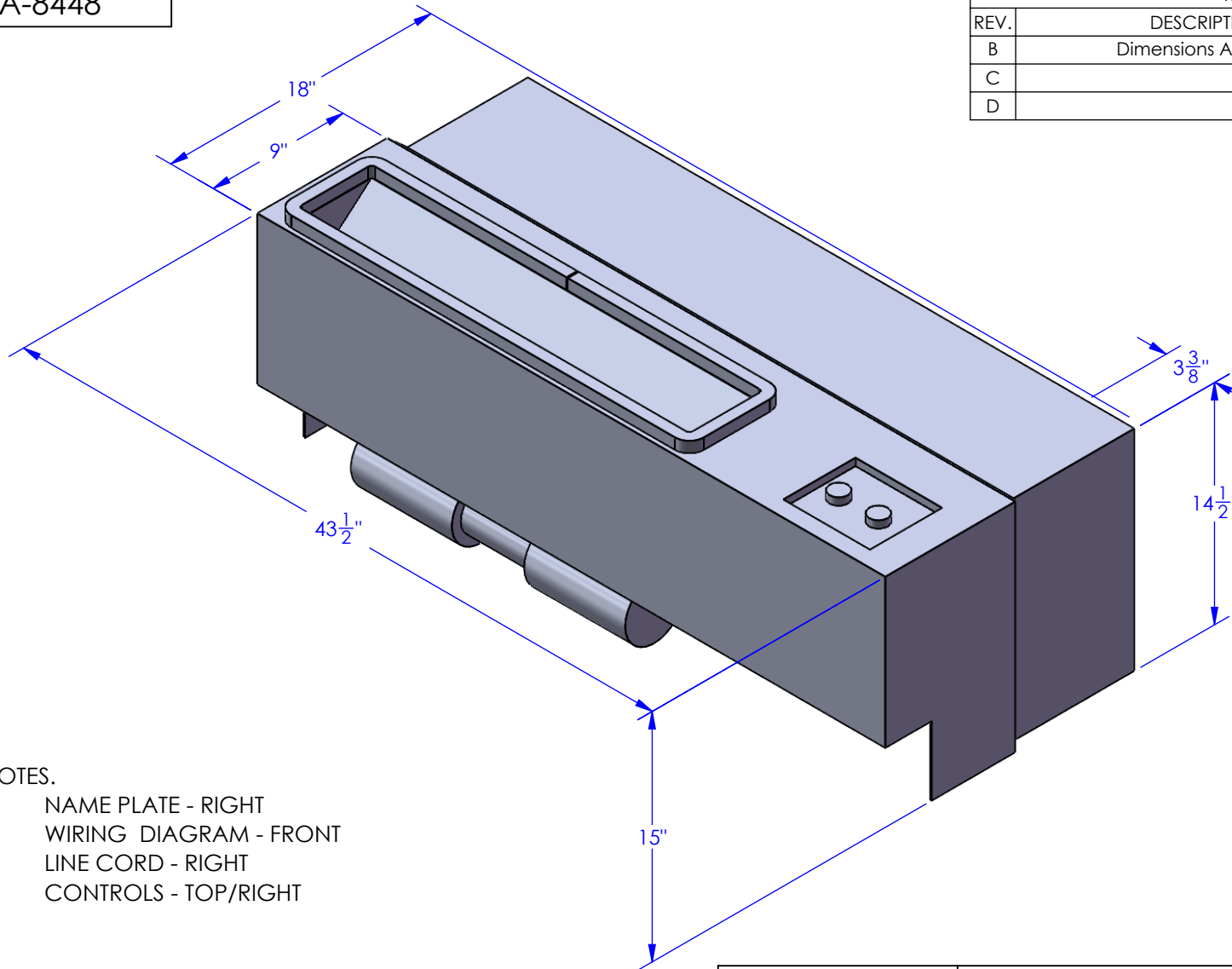

NOTES.

1. NAME PLATE - RIGHT
2. WIRING DIAGRAM - FRONT
3. LINE CORD - RIGHT
4. CONTROLS - TOP/RIGHT

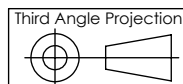

PROPRIETARY AND CONFIDENTIAL
 THIS DRAWING IS PROPERTY OF
ICE-AIR, LLC. IT MAY NOT BE
 REPRODUCED, DUPLICATED OR
 OTHERWISE COPIED WITHOUT
 PRIOR WRITTEN AUTHORIZATION.

MATERIAL:	ICE-AIR LLC. 80 HARTFORD AVENUE MOUNT VERNON, NY 10553		
WEIGHT (LBS):			
FINISH: N/A	TITLE: RSEA DIMENSIONAL DRAWING		
UNLESS OTHERWISE SPECIFIED: DIMENSIONS ARE IN INCHES TOLERANCES: FRACTIONAL ± 1/32 ANGULAR: MACH ± ° BEND ± 1° TWO PLACE DECIMAL ± .03 THREE PLACE DECIMAL ± .015	DRAWN BY: VP	DATE 02/27/08	DWG. NO. APA-8448
	APPROVED BY:	DATE	
	SIZE A	SCALE: NONE DO NOT SCALE DRAWING	REV C

PRODUCT SPECIFICATIONS
PACKAGED TERMINAL AIR CONDITIONER (PTAC)

ICE AIR HI SPEC™ UNITS

1. Equipment: Provide “RSEA” Series Packaged Terminal Air Conditioners (PTAC), as manufactured by Ice Air, LLC.
2. Components: Air conditioner to consist of wall sleeve, exterior louver, heating coil assembly, cooling chassis and room enclosure. Units to operate at either 115 volt, 208 / 230 volt, or 265 or 277 volt, single phase, 60 hertz circuits.
3. Wall Sleeves: Wall sleeve to be factory fabricated of 18 gauge galvanized steel and to be shipped with a mechanically-attached temporary coated cardboard filler panel at the exterior for weather protection. Cardboard filler panel to be removed prior to chassis and louver installation. Wall sleeve to have built-in pitch of at least ¼” and to be fabricated with an angled drain lip for proper drainage to the exterior of the building. Wall sleeves for masonry locations to be factory fabricated to match the full wall depth at each location; wall sleeves with field-installed extension pieces are not acceptable. Wall sleeves for panel wall locations are to be provided with adjustable-height support legs and galvanized steel sleeve angles to attach to the building panel wall system.
4. Louvers: Exterior louver to be horizontal, extruded aluminum blade-type construction with clear anodized (painted Duranar) finish. Louver to be supplied with stainless steel fastening hardware and must be capable of being installed from within the wall sleeve. Louvers at panel wall locations to be supplied by others.
5. Chassis: Cooling chassis to be a self-contained, slide-in assembly consisting of a sealed refrigerant system, evaporator and condenser sections with separate PSC motors (single motor units are not acceptable), manual (optional motorized) outside fresh air damper, unit mounted controls and line cord (junction box for 265 / 277 volt applications). Provide a permanent, washable aluminum mesh filter with each unit.
- 5a. Refrigeration System: Sealed refrigerant system to consist of high efficiency rotary compressor, copper tube / aluminum fin evaporator and condenser coils, refrigeration metering device consisting of a capillary tube expansion system and interconnecting tubing. System to be factory charged and sealed and capable of operating in the cooling mode to an outdoor ambient temperature of 35° F.
- 5b. Evaporator Section: Evaporator motor and blower wheels to be mounted on a slide-out, easily-removable motor board. Blower wheels to be metal double-inlet,

- forward curved centrifugal type, directly driven by a three-speed PSC motor with built-in automatic reset overload protector. Evaporator section to contain an integral galvanized steel motor / fan deck lined with an additional stamped and powder coated steel drain pan, draining into two 3/4" i.d. drain hoses (single drain units are not acceptable).
- 5c. Condenser Section: Condenser section to contain a separate PSC motor and metal propeller fan with an integral slinger ring. Condenser motor to cycle with compressor and to run during the cooling cycle only.
- 5d. Condensate Disposal: Condensate to drain from the indoor evaporator pan into the exterior galvanized steel condenser base pan through two 3/4" i.d. drain hoses. Condensate disposal to be accomplished by the entrainment of water particles in the condenser air stream and evaporation upon the hot condenser coil. No building condensate drain lines are to be required.
- 5e. Chassis Sheet Metal: Chassis sheet metal parts to be manufactured entirely of 18 gauge and 20 gauge galvanized steel. Chassis base pan to be powder coated inside and out to prevent corrosion of sheet metal pan. Chassis to be manufactured with an outsized indoor section that mates with the wall sleeve interior flanges and creates a positive weather seal using crushable pressure-sensitive foam tape, thereby preventing air and water infiltration. Chassis seal must be an integral part of unit construction, and use of attached sealing angles or channels is not acceptable.
- 5f. Unit Controls: Unit controls to include a six-position mode switch (Off – Heat – Hi Cool – Low Cool – Vent – Exhaust) and unit mounted rotary control thermostat. Include standard low-temperature control to activate motorized heating control valve below 45°F. interior room temperature, and Freezestat to be mounted on the evaporator coil only (condenser mounted freezestats are unacceptable) to provide true temperature readings.
6. Heating Assembly (Hydronic Heat): Heating Assembly to consist of a snap-in galvanized steel cradle and heating coil, with (Normally Open) (Normally Closed) motorized heating control valve. Motorized valve to be provided with Molex-type pin connector for plug-in electrical connection to the chassis, and to be actuated by the unit thermostat. Heating coil to be fabricated of copper tubing, mechanically expanded into aluminum fins. (Steam coil to be headered type) (Hot water coil to be serpentine type.). Coils to be supplied either right- or left-handed in quantities specified in building plans. Entire heat assembly to permanently mount onto the wall sleeve horizontally above cooling chassis and to have proper pitch built into the cradle assembly to ensure correct drainage of condensate water towards the return line in steam systems. Supply of all required valves and fittings, other than the motorized valve, is by others. Motorized valve to be shipped loose for field installation (optional factory attachment to heat assembly).

7. Room Enclosure (Cabinet): Room enclosure to be (flat top) (slope top) type and to be fabricated of 18 gauge galvanized paint grip furniture steel. Enclosure front cover to be fabricated from 20 gauge galvanized steel and to be removable without the use of tools. Enclosure to be finished in (Antique White) (Arctic White) baked powder coat finish. Room enclosure to mount to top flange of wall sleeve with integral threaded fasteners that align enclosure properly with chassis and heat assembly. Provide concealed flanges with clearance holes as an alternate means of enclosure attachment by fastening directly to the interior wall. Enclosure kick plate to be vertically adjustable, and to be shipped in correct field position (kick plates that require field labor to mount to enclosure are not acceptable).

8. Warranty and Code Compliance: Unit to be guaranteed free of defects in material and workmanship for one year from date of delivery. Provide (OPTIONAL) additional 2nd through 5th year compressor parts warranty. Units to be UL listed for safety in the United States and Canada, to have New York City MEA and BEC approvals, to be in compliance with all local, state and federal energy efficiency and building codes and to be tested in accordance with current ARI standards.