

Installation Manual

**FCHC
FCHU**

**Horizontal Concealed/
Horizontal Ultra Thin
Units**

Fan Coil Unit (FCU)



Contents

General/Safety Information	2
Overview/Application Note/Prerequisite	3
Before You Begin	4
Installation	5-6
Installing the Unit.....	5
Piping Installation	6
Duct Installation.....	5
Filter Installation/Replacement.....	6
General Wiring	7-8
System Cleaning and Flushing	9
Troubleshooting	10
System Check List	11
Product Nomenclature	11-14
Warranty/Contact Information	16

Thank you for purchasing and installing the Ice Air FCU (Fan Coil Unit). Ice Air is a leading supplier of FCUs, offering superior quality, reliability and efficiency for our customers.

This is a general guide only, and should be treated as such. The information contained in this manual, including but not limited to installation instructions, unit dimensions, and physical/performance data, may vary by project and unit configuration. Ice Air will not be held liable for any information contained in this manual. For questions about installation and unit performance, please contact your local Ice Air representative. Installation and start-up should always be performed by a trained professional.

ATTENTION INSTALLING PROFESSIONAL

Read this manual and familiarize yourself with the specific terms and safety warnings that must be adhered to before attempting to install or service this unit. Precautions listed are intended as supplemental to existing practices. As a professional, you have an obligation to know the product better than the customer. This includes all safety precautions and related items. It is your responsibility to install the product safely and know it well enough to be able to instruct a customer in its safe use as required.

RECOGNIZE THIS SYMBOL AS A SAFETY PRECAUTION.

- ▲ WARNING:** Ice Air will not be responsible for any injury or property damage arising from improper service or service procedures. If you install or perform service on this unit, you assume responsibility for any personal injury or property damage which may result. Many jurisdictions require a license to install or service heating and air conditioning equipment.
- ▲ WARNING, HIGH VOLTAGE:** Disconnect all power before servicing or installing unit. Multiple power sources may be present. Failure to do so may cause property damage, personal injury or death.

To ensure that the unit operates safely and efficiently, it must be installed according to these installation instructions and all local codes and ordinances, utilizing the best standards and practices at the time of installation or, in their absence, with the latest edition of the National Electric Code. The proper installation of this unit is described in the following sections. Following the steps in the order presented should ensure proper installation.

Overview

Installing the Ice Air Horizontal FCU's involves two main components and various accessory components.

Application Note

It is important for heating/cooling systems to be properly sized for each application in order to achieve desired temperature and humidity levels. It is highly recommended that a professional engineer match the FCU you are about to install with the building structure and climate.

Prerequisite

1. Locate the unit where it can evenly distribute air throughout the room without obstructions. Units should be installed no closer than 18" apart when two units are side by side. A vertical clearance of 60" should be maintained between units.
2. Adequate ceiling panel access must exist for hanger brackets, duct collars and fittings at water and electrical connections
3. A minimum obstructed distance of 36" should be kept around the unit.
4. Adequate and continuous water flow must be maintained for proper and safe unit operation. Ensure adequate drainage is also available.
5. Dedicated electrical circuitry and power supply is required to properly energize the Ice Air unit. Verify the amperage of the dedicated electrical service to the unit is correct and the unit can reach the power supply.
6. Please ensure the unit meets the guidelines of National Fire Protection Association (N.F.P.A.) Standard 90A or 90B regarding concealed units.

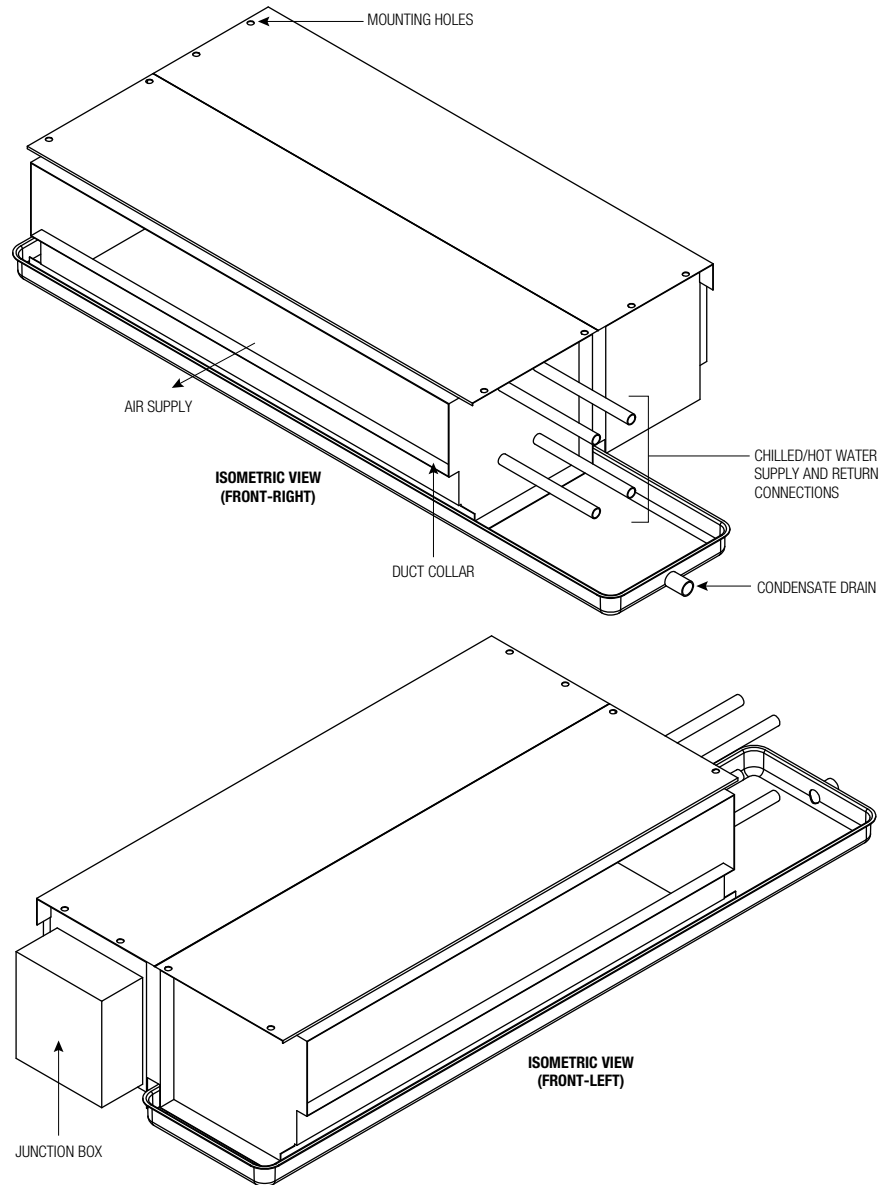

Before You Begin

1. Locate the unit where it can evenly distribute air throughout the room without obstructions. Units should be installed no closer than 12" apart when two units are side by side. A vertical clearance of 60" should be maintained between units.
2. Ensure the wall is structurally sound to support the weight of the unit.
3. Ensure adequate drainage is available.
4. Follow all applicable codes for installation.
5. Verify the amperage of the dedicated electrical service to the unit is correct and the unit can reach the power supply.
6. Position the unit so the air filter can be removed easily and required maintenance can be performed without interference.
7. A minimum obstructed distance of 36" should be kept around the unit.

IMPORTANT: To avoid permanent damage to the unit, DO NOT operate during construction in an open space or as a supplemental heating and cooling source during construction.

Inspection

1. Upon receipt of the equipment, carefully check the shipment again on the Bill of Lading.
2. Make sure all units have been received.
3. Inspect the packaging for any damage.
4. Ensure that any damage is noted on the delivering carriers Bill of Lading.

NOTE: It is the responsibility of the purchaser to file all necessary claims with the delivering carrier in a timely fashion. Many carriers have a 15 day notice period from receipt of delivery to file any and all claims.

Horizontal Concealed

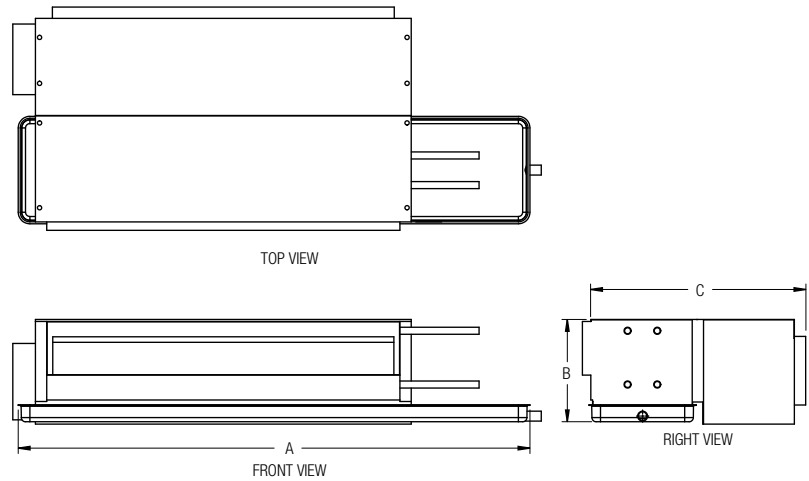

	FCHC02	FCHC03	FCHC04	FCHC06	FCHC08	FCHC10	FCHC12
"A" Width	30"	30"	41-3/4"	45-1/4"	59-1/2"	59-1/2"	67-3/4"
"B" Height	9"	9"	9"	9"	9"	9"	9"
"C" Depth	19-1/2"	19-1/2"	19-1/2"	19-1/2"	19-1/2"	19-1/2"	19-1/2"

Horizontal Ultra Thin

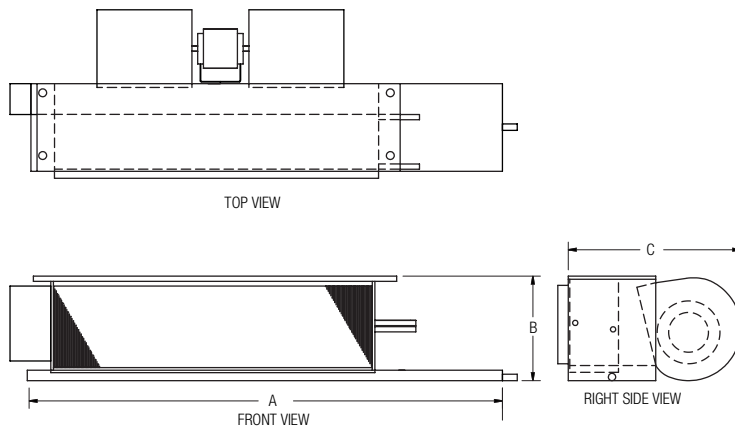

	FCHU02	FCHU03	FCHU04	FCHU06
"A" Width	30"	30"	41-3/4"	45-1/4"
"B" Height	8"	8"	8"	8"
"C" Depth	18-5/8"	18-5/8"	18-5/8"	18-5/8"

Installation

Installing the Unit

1. Ensure all preparations are met within the “Pre-Requisite Section.”
2. Within the concealed ceiling, mark the position of where threaded rods will attach to. Refer to the submittal for specific dimensions.
3. Embed four (4) threaded rods into the indicated positions. Ensure the ceiling is structurally intact to support weight of the unit. Refer to table at right for specific weights.
4. Connect the Ice Air unit to the threaded rods through the four (4) brackets on each corner. Attach a Vibrational Isolator beneath the bracket and a washer below that. Latch these pieces in place with a hex nut. Dual hex nuts are recommended as a precautionary measure (see below).
5. Ensure the discharge vent is level, otherwise adjust the threaded rods to correct the unit. **WARNING:** Do not loosen the nuts, this will increase the chance of vibrational failure.
6. Attach all necessary pipes and wiring connections. Additional ductwork should only be installed if instructed.
7. (RECESSED) Fasten the Access Panel to the bottom of the unit and tighten to the unit. Ensure the open panel is not fastened.
8. Run the unit.

FCHC/FCHU Weight Table				
Unit	Gross		Net	
	lbs.	kg.	lbs.	kg.
02	30	13.5	25	11
03	31	14	26.5	12
04	40	18	37.5	17
06	45	20.5	41	18.5
08	53	24	46	21
10	60	27	50.5	23
12	64	29	54	24.5

Threaded Rod Detail

- Bracket
- Vibration Isolator
- Washer
- Hex Nut
- Threaded Rod



Piping Installation

Ice Air's Horizontal Concealed Fan Coil is available in either 2 pipe or 4 pipe configurations (see below) that are connected to the system through the use of a flexible hose or rigid pipe. The piping system should be flushed to remove dirt, pipe shavings, chips and other foreign material prior to operation (refer to System Cleaning and Flushing section). The flow rate is generally set between 2 and 3 GPM per ton of cooling for most applications of water loop fan coils. To ensure proper maintenance and servicing, P/T ports are imperative for temperature and flow verification, as well as performance checks.

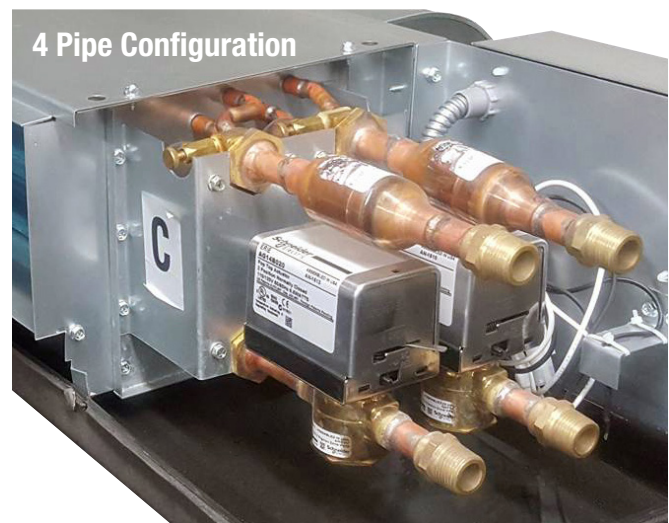

Installation

Ducting Installation

If the system calls for ducting, attach the duct to the duct collar on the supply vent. To secure the duct, fasten to collar until there is no exposed airflow (See right).

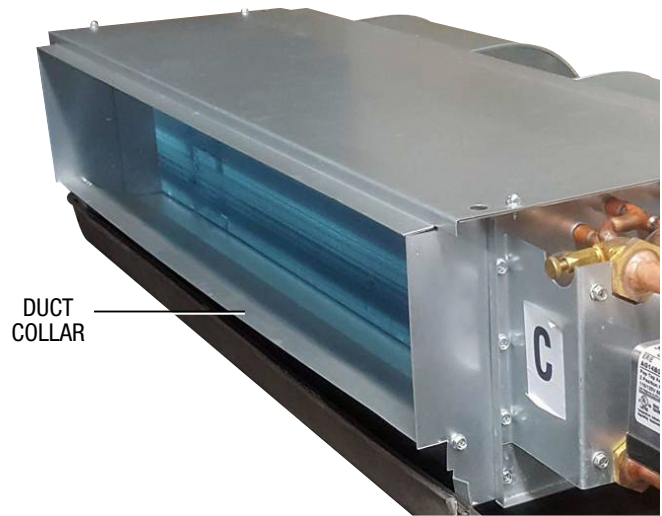

DUCT COLLAR

Filter Installation

Only configurations with a plenum on the return vent for the Horizontal Concealed Fan Coil are delivered with a filter. Filters are placed on the bottom slot and pressed forward into place.

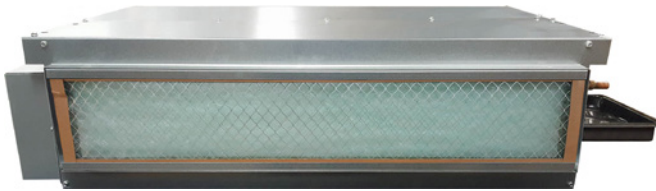

FILTER SHOWN INSTALLED

Filter Replacement

The Ice Air unit is delivered with a Disposable Filter. Disposable Filters should be replaced twice every year, before the start of every heating or cooling season. Please contact your local sales representative for replacements.



General Wiring

Line Voltage

Wiring, including the electrical ground, must comply with the National Electrical Code as well as all applicable local codes. Refer to the Electrical Data table for fuse sizes. Consult the wiring diagram below for field connections on the right of the electrical diagram located on the back of the unit electrical compartment front panel. All electrical connections must be made by the installing (or electrical) contractor. All final electrical connections must be made with a length of flexible conduit to minimize vibration and sound transmission to the building.

⚠ WARNING: Electrical shock can cause personal injury or death while installing or servicing the system. Always turn OFF the main power to system. There may be more than one disconnect switch.

General Line Voltage Wiring

Be sure the available power is the same voltage and phase shown on the unit serial number plate. Line and low voltage wiring must be done in accordance with local codes or the National Electric Code, whichever is applicable.

Power Connection

Units equipped with disconnect: Connect incoming line voltage to the disconnect switch and connect ground wire to the ground lug provided inside the electrical compartment.

Units without disconnect: Line voltage connection is made by connecting the incoming line voltage wires to the terminal block.

2 Pipe System

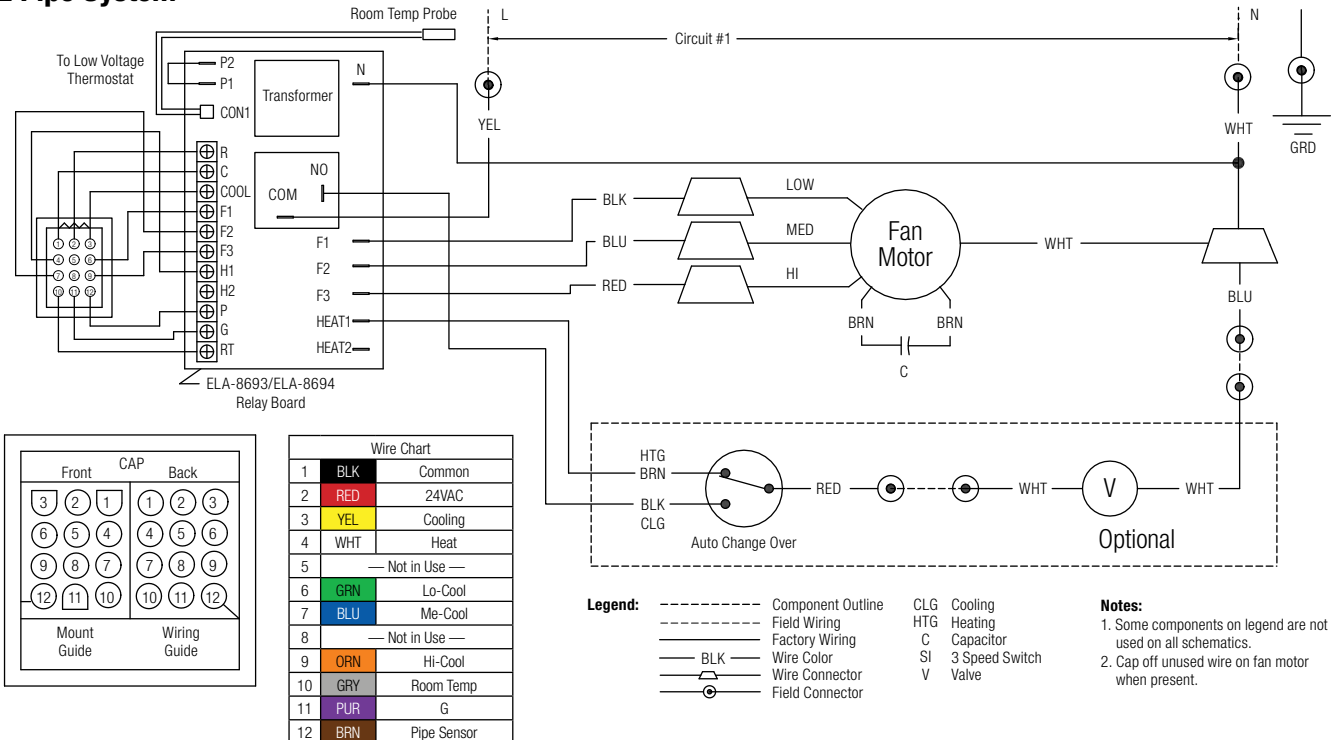

4 Pipe System

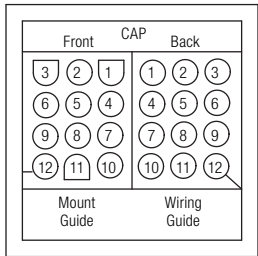
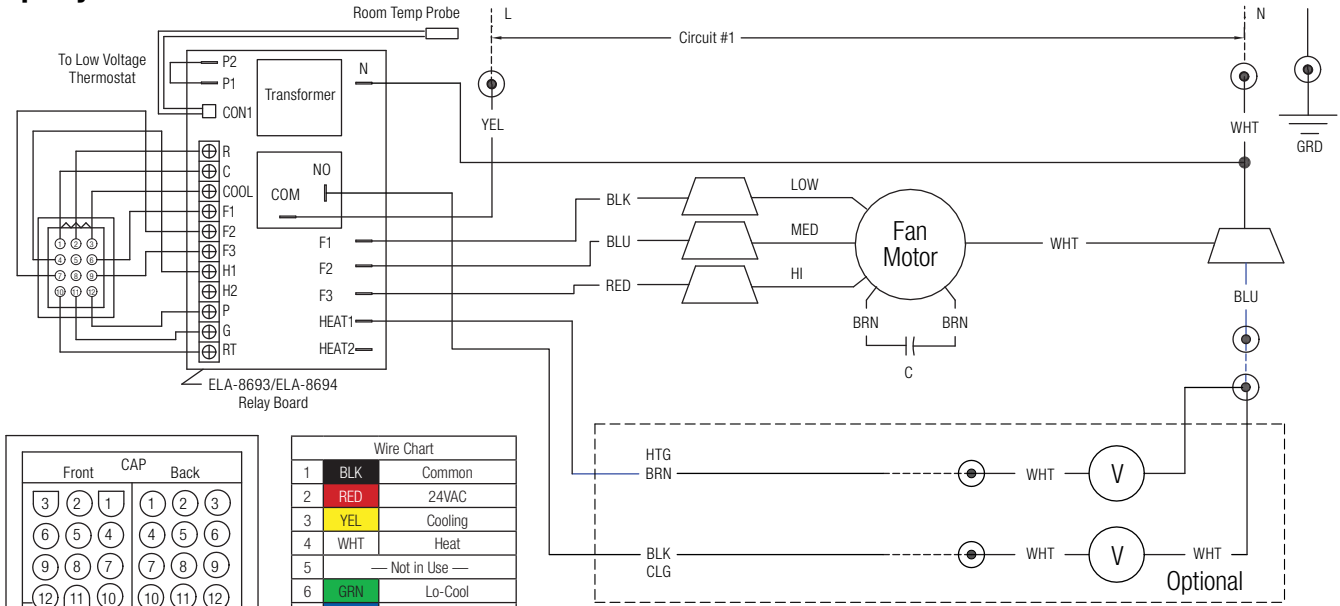

Wire Chart		
1	BLK	Common
2	RED	24VAC
3	YEL	Cooling
4	WHT	Heat
5		— Not in Use —
6	GRN	Lo-Cool
7	BLU	Me-Cool
8		— Not in Use —
9	ORN	Hi-Cool
10	GRY	Room Temp
11	PUR	G
12	BRN	Pipe Sensor

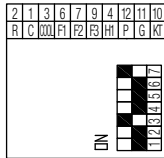
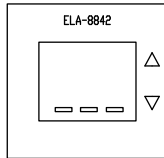

Legend:	----- Component Outline	CLG	Cooling
	----- Field Wiring	HTG	Heating
	----- Factory Wiring	C	Capacitor
	BLK	SI	3 Speed Switch
	Wire Color	V	Valve
	Wire Connector		
	Field Connector		

- Notes:**
1. Some components on legend are not used on all schematics.
 2. Cap off unused wire on fan motor when present.

Evaporator speeds configuration
 Cooling – HI or MED
 Heating – MED or LOW

System Cleaning and Flushing

Cleaning and flushing the unit is the most important step to ensure proper start-up and continued efficient operation of the system. Follow the instructions below to properly clean and flush the system:

1. Verify that electrical power to the unit is OFF.
2. Verify that supply and return riser service valves are closed at each unit.
3. Fill the system with water, leaving the air vents open. Bleed all air from the system, but do not allow the system to over flow. Check the system for leaks and make any required repairs.
4. Adjust the water and air level in the expansion tank.
5. With strainers in place, start the pumps. Systematically check each vent to ensure that all of the air is bled from the system.
6. Verify that make-up water is available and adjusted to properly replace any space remaining when all air is purged. Check the system for leaks and make any additional repairs if needed.
7. Set the boiler to raise the loop temperature to approximately 85°F (29.4°C). Open the drain at the lowest point in the system. Verify that make-up water replacement rate equals rate of bleed. Continue to bleed the system until the water appears clean or for at least three hours, whichever is longer.
8. Completely drain the system.

Troubleshooting

IMPORTANT: It is not the intent of this maintenance manual to resolve any problems with the operation of your Ice Air unit. Please contact a trained servicer or building maintenance staff immediately if your unit fails to perform properly.

1. Contact a trained service technician to conduct full unit diagnostics and repair to equipment.
2. Record any unit that does not operate noting the unit serial number on your report.

⚠️ RECOGNIZE THIS SYMBOL AS A SAFETY PRECAUTION.

⚠️ WARNING: Ice Air will not be responsible for any injury or property damage arising from improper service or service procedures. If you install or perform service on this unit, you assume responsibility for any personal injury or property damage which may result. Many jurisdictions require a license to install or service heating and air conditioning equipment.

⚠️ WARNING HIGH VOLTAGE: Disconnect all power before servicing or installing unit. Multiple power sources may be present. Failure to do so may cause property damage, personal injury or death.

If unit is not operating, conduct the following checks:

1. Check the electrical connections.
2. Check the voltage and current against the electrical specifications on the unit nameplate.
3. Look for wiring errors. Check for loose screw connections in both line and low voltage terminals.
4. Check the water supply piping for proper water connection.
5. Check for dirty filters.
6. Check indoor fan for proper operation.
7. Check that unit did not cycle off due to improper thermostat settings.
8. Check for fault codes on the control board – consult the Board Troubleshooting Table.



System Check List

Installer: Complete unit and system checkout and follow unit start-up procedures provided with the unit. Use this form to record information, temperatures and pressures during start-up. Keep this form for future reference.

Location Information.

Owner: _____

Address: _____

Model Number: _____

Serial Number: _____

Unit Location in Building: _____

Date: _____

Sales Order No: _____

In order to minimize troubleshooting and costly system failures, complete the following checks and data entries before the system is put into full operation.

Temperatures: (Circle) F or C

Antifreeze: _____ Type: _____ %

Pressures: (Circle) PSIG or kPa

Allow unit to run 15 minutes in each mode before taking data.

Do not connect service manifold gauges during start up unless instructed by Ice Air service tech.

	Cooling Mode	Heating Mode
Return-Air Temperature DB (°F)		
Supply-Air Temperature DB (°F)		
Temperature Differential		
Entering Fluid Temperature (°F)		
Leaving Fluid Temperature (°F)		
Temperature Differential		
Water Pressure IN		
Water Pressure OUT (PSI)		
Pressure Differential (PSI)		
Flow Rate (GPM)		
Supply Voltage at Contactor (V)		
Transformer Low Side Volts (V)		
Compressor Amps (A)		
Motor Amps (A)		

Precautions and preparations listed are for general knowledge and to define basic guidelines. Local codes and existing practices should be observed and preformed by a professional. Due to Ice Air's ongoing product development programs, the information in this document is subject to change without notice.

Product Nomenclature

Model Selection **8** **FCHC** **02** **F** **P** **A** **L** **X** **A** **A** **X** **X** **L** **A** **A** **A** **B** **B** **Y** **D** **P** **A** **A** **S** **A**

1 2 3 4 5 6 7 8 9 10 11 12 13 14 15 16 17 18 19 20 21 22 23 24 25 26

└──────────┘

Primary Part

Item #	Matrix Name	Code String Value	Description
1	POWER	5	115V/1Ph/60Hz
		8	208V/1Ph/60Hz
		7	277V/1Ph/60Hz
2	UNIT TYPE	FCHC	Horizontal Concealed Fan Coil
		FCHU	Horizontal Ultra-Thin Fan Coil
3	CAPACITY (BTUH)	02	200 CFM
		03	300 CFM
		04	400 CFM
		06	600 CFM
		08	800 CFM
		10	1000 CFM
		12	1200 CFM
		16	1600 CFM (FCHC Only)
		18	1800 CFM (FCHC Only)
4	ELECTRIC CONN.	F	Fused Disconnect switch
		N	Non-Fused Disconnect Switch
		X	No Disconnect - terminal block only
5	MOTOR	P	PSC Motor
		S	Hi-static PSC Motor
		E	EC Motor
6	COIL CONFIG	A	2-Pipe, 2-Row
		B	2-Pipe, 3-Row
		C	2-Pipe, 4-Row
		D	4-Pipe, 1-Row-H, 1-Row-C
		E	4-Pipe, 1-Row-H, 2-Row-C
		F	4-Pipe, 1-Row-H, 3-Row-C
		G	4-Pipe, 1-Row-H, 4-Row-C
		J	4-Pipe, 2-Row-H, 4-Row-C
		I	4-Pipe, 2-Row-H, 3-Row-C
7	PIPE ORIENTATION	L	Left Hand Connections
		R	Right Hand Connections
		A	4P: LH Heat; RH Cool
		B	4P: RH Heat; LH Cool
		C	4P: Heat: LH Supply/RH Return; Cool: LH Supply/RH Return
		D	4P: Heat: RH Supply/LH Return; Cool: LH Supply/RH Return
		E	4P: Heat: LH Supply/RH Return; Cool: RH Supply/LH Return
		F	4P: Heat: RH Supply/LH Return; Cool: RH Supply/LH Return
		U	4P: Rear LH Heat; Rear RH Cool
V	4P: Rear RH Heat; Rear LH Cool		

Item #	Matrix Name	Code String Value	Description
8	ELECTRIC HEAT	X	No electric heat
		B	1.0 - kW Electric Heat
		C	1.5 - kW Electric Heat
		D	2.0 - kW Electric Heat
		E	3.0 - kW Electric Heat
		F	3.5 - kW Electric Heat
		G	4.3 - kW Electric Heat
		H	5.0 - kW Electric Heat
		I	6.0 - kW Electric Heat
		J	7.5 - kW Electric Heat
		K	10 - kW Electric Heat
9	CHANGE OVER	A	Automatic change over
		M	Manual
		X	No change over
10	CONTROLS	A	Fan Mode Dial (ELA-9859)
		B	Manual Temperature Dial with Fan Mode Dial (ELB-1017(L); ELA-9859(R))
		C	Non-Programmable LCD Touchpad Thermostat (ELA-12690)
		D	Non-Programmable LCD Thermostat (ELA-8842 via dip switch)
		E	7-Day Programmable LCD Thermostat (ELA-8842)
		F	7-Day Programmable Touchscreen Thermostat (ELA-13086)
		G	Nest Thermostat (ELA-10665)
		H	Habitat Wireless Wi-Fi Thermostat with Water Leak Detector (ELA-13161)
		I	Non-Programmable LED Touchpad Thermostat (ELA-10328)
		X	Thermostat Field Mounted By Others
11	WIRE WHIPS	A	Wall Mounted with 6.5-foot wire whip
		B	Wall Mounted with 10-foot wire whip
		C	Wall Mounted with 12-foot wire whip
		D	Wall Mounted with 30-foot wire whip
		E	Wall Mounted with 50-foot wire whip
		F	Standard 18" Wire Whip
		U	Unit Mounted Controls
12	ENCLOSURE	1	Antique White Enclosure
		2	Arctic White Enclosure
		3	Custom Color Enclosure
		4	Custom Size Antique White Enclosure
		5	Custom Size Arctic White Enclosure
		6	Custom Size Custom Color Enclosure
		X	Not Applicable



Product Nomenclature

Model Selection 8 FCHC 02 F P A L X A A A X X L A A A B B Y D P A A S A

 1 2 3 4 5 6 7 8 9 10 11 12 13 14 15 16 17 18 19 20 21 22 23 24 25 26

 └──────────┘

 Primary Part

Item #	Matrix Name	Code String Value	Description
13	PLENUM	B	Bottom Return Plenum
		F	Front Return Plenum
		R	Rear Return Plenum
		X	Not Applicable
14	VALVE VOLTAGE	L	Line Voltage Valve Power
		2	24 VAC Valve Power
		X	No Valve Power
15	VALVE BODY	A	Valve Field Mounted by Other (Wire Whip Factory Installed)
		B	2-Way Motorized Valve Body
		D	2-Way Pressure Independent Control Valve Body
		E	3-Way Motorized Valve Body, Diverting
		G	3-Way Motorized Valve Body, Diverting with Bypass
		I	3-Way Motorized Valve Body, Routing
		K	3-Way Motorized Valve Body, Routing with Bypass
		M	6-Way Mixing Valve Body
X	No Valve Body		
16	VALVE ACTUATOR	A	2-Way Motorized Valve NO
		C	2-Way Motorized Valve NC
		E	2-Way Modulating Control Valve NO
		G	2-Way Modulating Control Valve NC
		Y	Valve Actuator Field Installed
		X	No Valve Actuator
17	DRAIN PAN	A	Galvanized Powder Coated Drain Pan - primary and secondary; no cond. overflow switch
		B	Galvanized Powder Coated Drain Pan - primary and secondary; electronic cond. overflow switch
		C	Galvanized Powder Coated Drain Pan - primary only; no cond. overflow switch
		D	Galvanized Powder Coated Drain Pan - primary only; electronic cond. overflow switch
		E	Galvanized Powder Coated Drain Pan - primary; Stainless steel - secondary; no cond. overflow switch
		F	Galvanized Powder Coated Drain Pan - primary; Stainless steel - secondary; electronic cond. overflow switch
		G	Stainless Steel Drain Pan - primary and secondary; no cond. Overflow switch
		H	Stainless Steel Drain Pan - primary and secondary; electronic cond. Overflow switch
		I	Stainless Steel Drain Pan - primary only; no cond. overflow switch
		J	Stainless Steel Drain Pan - primary only; electronic cond. overflow switch
		K	Stainless Steel Drain Pan - primary; Galvanized powder coated - secondary; no cond. overflow switch
		L	Stainless Steel Drain Pan - primary; Galvanized powder coated - secondary; electronic cond. overflow switch
		M	Plastic Drain Pan - primary and secondary; no cond. Overflow switch
		N	Plastic Drain Pan - primary and secondary; electronic cond. Overflow switch
X	No Drain Pan		

Item #	Matrix Name	Code String Value	Description
18	FLOW VALVE CW	B	Circuit Setter (B&G Calibrated Balancing Valve)
		C	Autoflow valve - 0.5 gpm
		D	Autoflow valve - 1.0 gpm
		E	Autoflow valve - 1.3 gpm
		F	Autoflow valve - 1.5 gpm
		G	Autoflow valve - 2.0 gpm
		H	Autoflow valve - 2.5 gpm
		I	Autoflow valve - 2.8 gpm
		J	Autoflow valve - 3.0 gpm
		K	Autoflow valve - 3.3 gpm
		L	Autoflow valve - 3.5 gpm
		M	Autoflow valve - 4.0 gpm
		N	Autoflow valve - 4.5 gpm
		O	Autoflow valve - 5.0 gpm
		P	Autoflow valve - 5.5 gpm
		Q	Autoflow valve - 6.0 gpm
		R	Autoflow valve - 6.5 gpm
		S	Autoflow valve - 7.0 gpm
		T	Autoflow valve - 7.5 gpm
		U	Autoflow valve - 8.0 gpm
V	Autoflow valve - 8.5 gpm		
W	Autoflow valve - 9.0 gpm		
Y	Autoflow valve - 9.5 gpm		
Z	Special		
X	No Flow valves		

Precautions and preparations listed are for general knowledge and to define basic guidelines. Local codes and existing practices should be observed and performed by a professional. Due to Ice Air's ongoing product development programs, the information in this document is subject to change without notice.



Product Nomenclature

Model Selection 8 FCHC 02 F P A L X A A A X X L A A A B B Y D P A A S A

 1 2 3 4 5 6 7 8 9 10 11 12 13 14 15 16 17 18 19 20 21 22 23 24 25 26

 └──────────┘

 Primary Part

Item #	Matrix Name	Code String Value	Description
19	FLOW VALVE HW	A	Autoflow valve (without y-strainer) [do not use]
		B	Circuit Setter (B&G Calibrated Balancing Valve)
		C	Autoflow valve - 0.5 gpm
		D	Autoflow valve - 1.0 gpm
		E	Autoflow valve - 1.3 gpm
		F	Autoflow valve - 1.5 gpm
		G	Autoflow valve - 2.0 gpm
		H	Autoflow valve - 2.5 gpm
		I	Autoflow valve - 2.8 gpm
		J	Autoflow valve - 3.0 gpm
		K	Autoflow valve - 3.3 gpm
		L	Autoflow valve - 3.5 gpm
		M	Autoflow valve - 4.0 gpm
		N	Autoflow valve - 4.5 gpm
		O	Autoflow valve - 5.0 gpm
		P	Autoflow valve - 5.5 gpm
		Q	Autoflow valve - 6.0 gpm
		R	Autoflow valve - 6.5 gpm
		S	Autoflow valve - 7.0 gpm
		T	Autoflow valve - 7.5 gpm
		U	Autoflow valve - 8.0 gpm
		V	Autoflow valve - 8.5 gpm
		W	Autoflow valve - 9.0 gpm
Y	Autoflow valve - 9.5 gpm		
Z	Special		
X	No Flow valves		

Item #	Matrix Name	Code String Value	Description
20	STRAINER	Y	Y-strainer
		B	Y-strainer with Blowdown
		X	No strainer
21	DRAIN VALVE	D	Drain Valve with Isolation Valve and Hose Connection
		X	No Drain Valve
22	PT PORTS	P	PT Ports (on supply and return)
		S	PT Ports on Supply
		R	PT Ports on Return
		X	No PT Ports
23	AIR VENT	A	Automatic Air Vent
		M	Manual Air Vent
		X	No Air Vent
24	PIPE FITTINGS	A	Female NPT Pipe Fittings
		C	Male NPT Pipe Fittings
		E	Sweat Pipe Fittings
		G	Union Pipe Fittings
		I	Isolation Valves with Unions
		K	Isolation Valves with Female NPT Connections
		M	Isolation Valves with Male NPT Connections
		O	Isolation Valves with Sweat Connections
25	FILTER	S	Standard Fiberglass Filter
		T	MERV 8 Filter
		V	MERV 13 Filter
26	VALVE SHIPPING OPTIONS	A	Assembled
		S	Shipped Loose
		X	No Valve Package

Precautions and preparations listed are for general knowledge and to define basic guidelines. Local codes and existing practices should be observed and performed by a professional. Due to Ice Air's ongoing product development programs, the information in this document is subject to change without notice.



Notes or Technical Comments

Precautions and preparations listed are for general knowledge and to define basic guidelines. Local codes and existing practices should be observed and performed by a professional.
Due to Ice Air's ongoing product development programs, the information in this document is subject to change without notice.



Limited Warranty

Twelve (12) Month Warranty of entire Packaged Terminal Equipment

Ice-Air, LLC ("Ice Air" or the "Company") warrants, solely to the person or entity that directly purchased the packaged terminal system from the Company (the "Original Owner"), that the entire packaged terminal system is free from defects in material and workmanship for a period of twelve (12) months from the date of delivery (the "Twelve Month Warranty"). Any part or portion thereof which becomes defective under normal use during the period of this warranty will be repaired or replaced, provided Ice Air's examination shall prove to its satisfaction that the part was or became defective under normal use. Ice Air's obligations under this warranty are subject to the satisfaction of the conditions set forth in the last paragraph of this Section and are limited to: (a) repairing the defective part or (b) furnishing a replacement part provided the defective part is returned to Ice Air, without shipping damage, transporting charges prepaid. No reimbursement will be made for expenses incurred in making field adjustments or replacements unless specifically authorized in writing by the Company.

Except as otherwise provided in the last sentence of this paragraph, the Company is not obligated under this warranty for field labor such as service for inspection, removing, packing and/or reinstalling water source unit, nor for the return transportation charges. In addition, the Company is not obligated under this warranty to make reimbursement of the labor or service charges of any other party. Notwithstanding the foregoing, labor provided by or at the direction of the Company during the twelve (12) month period from the date of delivery referred to in the initial paragraph above, in connection with the Twelve Month Warranty of parts provided in the initial paragraph above, is included in such warranty, solely in the case in which a packaged terminal system is sold by the Company to an Original Owner for use in a new facility to be constructed and located in the greater New York City metropolitan area. For the avoidance of doubt, except in the case described in the preceding sentence, the Company has no obligation under this warranty to provide for field labor or to make reimbursement of the labor or services charges of any other party, provided, however, that the Company, in its sole and absolute discretion, may elect to do so, so long as (i) such election is set forth in a writing signed by the Company and (ii) the facility at which the applicable packaged terminal system is or will be installed is located in the greater New York City metropolitan area (the "Metropolitan Area").

The obligations of the Company set forth in the preceding paragraphs of this Section are in all cases subject to the satisfaction of the following conditions: (x) the Company shall have received proof, satisfactory to the Company, of the purchase by the Original Owner from the Company of the packaged terminal system that is the subject of the Original Owner's claim, (y) all amounts due and payable to the Company on or prior to the date of such claim in respect of such packaged terminal system shall have been paid in full and (z) nothing shall exist or occur that relieves the Company, in accordance with the terms of this agreement, from the performance of its warranty obligations hereunder.

OPTIONAL Extended Refrigeration Circuit Warranty

2nd – 5th year compressor parts only; labor not included

The Optional Extended Refrigeration Circuit Warranty MUST be purchased from Ice Air within thirty (30) days from date of delivery to be valid. The hermetically sealed refrigeration circuit (consisting of the motor, compressor assembly, evaporator coil, coaxial / condenser coil, and interconnecting tubing) is warranted to the Original Owner for four additional years from date of the expiration of the twelve-month Warranty. Components under this warranty will be supplied at Ice Air's expense provided the failed component is returned to Ice Air. This optional warranty does not include any other parts of the equipment such as fans, fan motors, controls, cabinet parts, electrical relays, capacitors, protective devices, or wiring. Ice Air is not obligated under this warranty for field labor such as service for inspection, removing, packing, and/or reinstalling the refrigeration circuit, nor for return transportation charges. In addition, the Company is not obligated under this warranty to make reimbursement of the labor or service charges of any other party. Ice Air reserves the right to make a handling and inspection charge in the case of parts or equipment improperly returned as defective and/or as being in warranty.

To obtain assistance under the parts warranty or to purchase the optional extended warranty, simply contact Ice Air Customer Service at 80 Hartford Avenue, Mount Vernon, New York 10553 Phone 914-668-4700.

Additional warranty options include:

2nd – 5th year full unit parts only warranty

2nd – 5th year compressor parts and labor warranty, so long as such labor is performed in the NY Metropolitan Area

2nd – 5th year complete parts and labor warranty (Full unit coverage), so long as such labor is performed in the NY Metropolitan Area.

All Warranties (which must be purchased separately) constitute the Original Owner's sole remedy. They are given in lieu of all other warranties. Ice Air is not liable for incidental or consequential damages, whether the theory is breach of this or any warranty, negligence, or strict tort. No person (including any agent, salesman, dealer, or distributor) has authority to expand Ice Air's obligation beyond the terms of these express warranties, or to state that the performance of the product is other than that published by Ice Air. In addition, neither the Original Owner nor any such person has the right to sell, transfer or assign, or attempt to sell, transfer or assign, any rights of the Original Owner in or to the warranties provided for herein, no such sale, transfer or assignment shall be binding upon Ice Air and any such sale, transfer or assignment is null and void and of no force or effect.

General Conditions

The above warranties are void if Ice Air's equipment has been damaged, misused, subjected to abnormal use or service or its serial number has been altered, defaced, or removed, or payment for the equipment is in default. Ice Air is not responsible for service to correct conditions due to misapplication, faulty or improper installation, inadequate wiring, incorrect voltage conditions or unauthorized opening of the refrigeration circuit, nor for consequential damages. In case Ice Air's equipment is installed in conjunction with cabinets, grills, louvers, controls, or other parts manufactured by others, these warranties shall apply only to Ice Air's manufactured portion of the equipment. The conditions of the standard warranty plan are effective for 12 months from the date of equipment delivery. Ice Air reserves the right to make a handling and inspection charge in the case of parts or equipment improperly returned as defective and/or as being warranty.

Important Disclaimers Ice Air Has No Responsibility For:

(A) Certain Damages

The following are the responsibility of the user. None of the following constitutes a manufacturing defect, and each is expressly excluded from the warranty plan:

- 1) Failure of unit to operate satisfactorily due to improper amount of air on evaporator coil or air supply to air cooled condensers.
- 2) Damage to unit or unsatisfactory operation due to improper cleaning of evaporator coil or use of unit in corrosive atmosphere locations such as chemical plants, refineries, or salt spray areas.
- 3) Damage to unit from unsatisfactory operation due to blown fuses, inadequate or interrupted electrical service, use of improper electrical protective devices or operation of unit on power supply other than covered by nameplate rating of unit.
- 4) Damage due to failure to properly maintain unit.
- 5) Damage due to transportation or handling prior to and during installation.
- 6) Damage due to accident or from alteration, improper installation or tampering.
- 7) Failure to clean or replace filter timely.
- 8) Misapplication of equipment.
- 9) Damage due to deviation from original design and intended use of equipment.
- 10) Damage due to use of additional accessories either unapproved or approved but modified or manipulated.

(B) Installation

Ice Air is not responsible for the design, execution, and performance of the installation method or any of the accessory items used during installation such as seals, caulking, weatherproofing, supporting structures, attachment means, louvers and frames supplied by others.

(C) Check, Test and Start

Check, Test and Start of the air conditioners by an experienced person is the responsibility of the installing contractor. This consists of physically confronting each conditioner operating in both heating and cooling modes and correcting any minor deficiencies noted. After the equipment leaves the factory, it may become damaged or maladjusted during transportation or on the job. Sometimes wires are disconnected accidentally, or fan motors move on their bases due to rough handling, causing fans to strike; a component(s) may be inoperable. The correction of such conditions is part of the Check, Test and Start. Note that unless otherwise specifically agreed to in writing, Ice Air has no obligation to perform, nor does the price of its equipment include field labor in connection with the performance of, these Check, Test, and Start procedures (or the like).



80 Hartford Avenue, Mount Vernon, NY 10553
Tel: 877-ICE-AIR-1 (877-423-2471)
Fax: 914-668-5643
email: service@ice-air.com

www.ice-air.com

© 2023 by Ice Air, LLC

ICE6090.1 11/23